

Ikegami

HDN-X10

Genuine HD Production System

Editcam *HD*

HDTV Tapeless Camera/Recorder **HDN-X10**



HDTV Tapeless Camera/Recorder HDN-X10

The HDN-X10 is a sophisticated camera, optimized for all kinds of shooting in the production environment, producing non-linear recordings to seamlessly integrate with high end HD post production.



Genuine Full HD Resolution



Genuine HD Quality



Genuine Tapeless Camera



Technology to realize Genuine Full HD Resolution

Full HD 1920×1080 Recording

High quality 2,500,000 pixel COMS sensors capture Full HD 1920×1080 pixel HDTV image, and the image is recorded with DNxHD compression without down sampling. HDTV resolution will not be reduced in the acquisition stage.

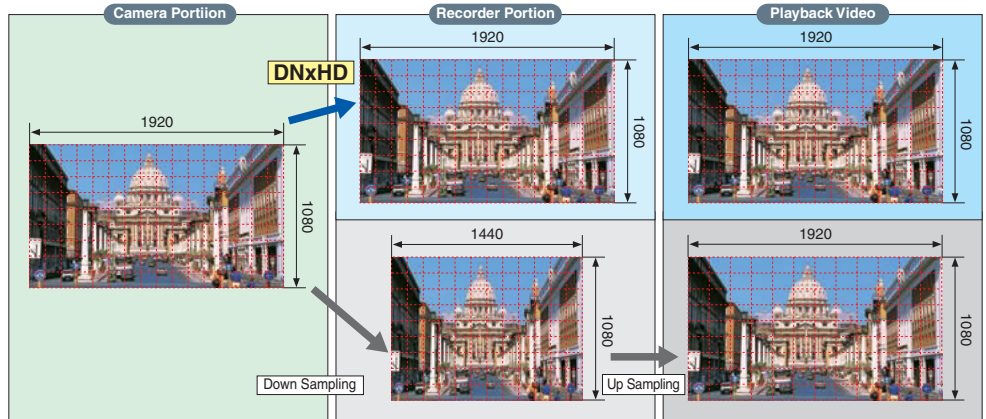

Avid DNxHD Codec

Avid developed DNxHD Codec which provides high quality video image with evolutionary technology. Uncompressed 1.2Gbps HD SDI signal is compressed efficiently to a file size about the same as an uncompressed SD SDI signal. The DNxHD Codec supports 8-bit and 10-bit quantization at 145Mbps and 220Mbps respectively, allowing the user to balance performance versus file size for the particular application.

The HDN-X10, Editcam HD supports 8bit/145Mbps compression currently and will support 220Mbps compression in the near future. Not only 1080/59.94i, but also 1080/50i, 1080/23.98p, 720/59.94p and 720/50p formats are supported.

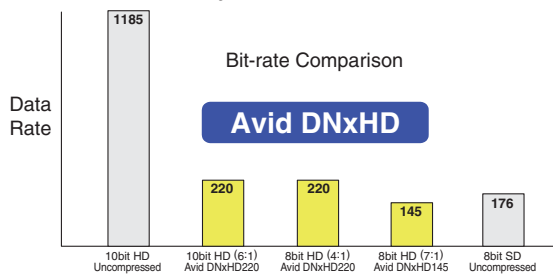

Uncompressed Video



Avid DNxHD 145 Video

* Image Samples

Technology to realize Genuine HD Quality

CMOS Sensors

The CMOS Sensor doesn't use vertical charge transfer like a CCD Sensor so no vertical smear is generated in the CMOS Sensor. By incorporating System-on-Chip technology, these CMOS Sensors include Digital Noise Reduction, Digital Low-pass Filter and 14-bit DSP Circuit inside of the Sensor itself to reduce Random Noise and Fixed Pattern Noise, as well as, improving Dynamic Range.

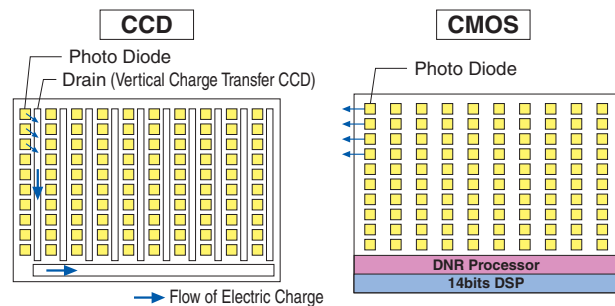
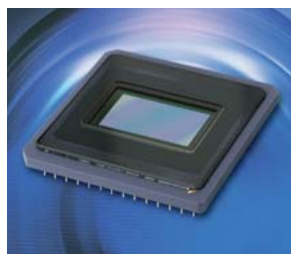

Chip C4 ASIC

The DSP IC named "Chip C4" employs up to 38-bit digital processing, and includes technology from Ikegami's vast experience in developing successful broadcast cameras over the years, including 'Ikegami Color'. Nonlinear processing such as White Shading and Gamma Curve Compensation are performed digitally, providing stable high quality pictures.

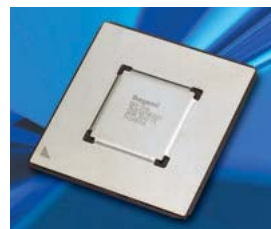

YUV 4:2:2 Color Sampling

4:2:2 Digital Component Recording ensures color resolution to meet the demand for the top end production such as HD production and Chroma-key Effects.

Technology to realize Genuine Tapless Camera



Full Compatibility with Avid NLEs (Nonlinear Editors)

Recorded material (Video/Audio/Meta-data) in FieldPak2 can be edit by Avid NLE right after the FieldPak2 is mounted onto the Avid NLE. Since neither Capturing nor File Coping is required, work efficiency is raised significantly.

Meta-data Page (HDN-X10)



Recording Media

The removable media, FieldPak2, employs a cost effective Hard Disk Drive with anti-vibration/anti-shock package. Operation is almost the same as SDTV, even though HDTV has a much higher data rate recording/playing. Not only current Hard Disk Drive, FieldPak2 has been designed to employ any media which will be de facto standard from the media capacity or read/write speed point of view.



Unique Nonlinear Recording

■ Retro-loop

The HDN-X10 can make loop-recording for video and audio to FieldPak2 with a preset cache time.

An important shot can be recorded even though the REC button is pressed after an event occurs.

■ Time-lapse Recording

Shooting for very slow moving object like Blooming of flower, movement of cloud, or clay animation, is possible using interval frame recording.

■ Intelligent Recording

The HDN-X10 can always access the full capacity of FieldPak2. If REC button is pressed when recorded clip is playing, the played clip will not be overwritten, and recording will start immediately.



Meta-data Table (Avid NLE) *

Stored Meta-data on the camera is displayed in the bin summary on the NLE application. By inputting related data for the material such as Cameraman Name, Shooting Location or Program Name, these Meta-data can be confirmed and Keyword search is available during editing. It supports easier editing or easier material management.

System Application

Proxy (Option)

Create and record low bit rate (350Kbps to 3Mbps selectable) Windows Media9, Proxy Video Clip File in FieldPak2. Proxy Video includes Meta-data input by camera operation. When Proxy Video is transferred from remote location via IP network, not only Video Clip but also Meta-data is also transmitted.

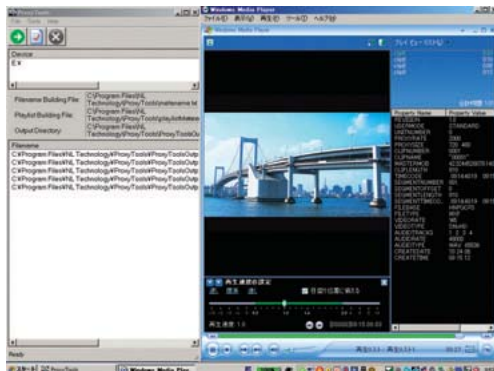

Proxy Viewer/Windows MediaPlayer Screen Shot *

USB Keyboard Support (Option)

By connecting conventional USB Keyboard to USB Port, Meta-data input and Simple Editing Control are available. Play List Data edited on camera head can be imported into Avid NLE as a sequence.



* Image Samples

Optical Fiber Transmission System (Option)

By attaching FE-C100A Fiber Camera Adaptor, HD-SDI with embedded Audio can be transmitted up to 2km (1.2mile) to the FE-B100A Base Station. Return Video (HD-SDI), Intercom, Genlock and camera control are also supported.

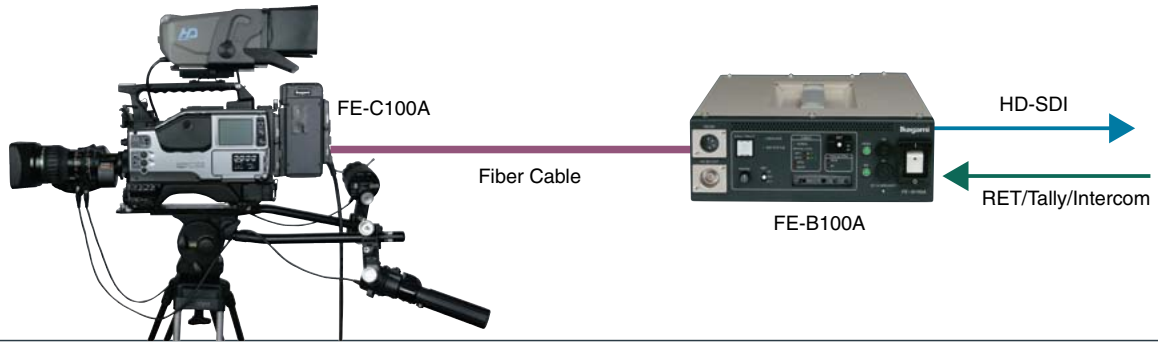

Wireless Camera System (Option)

By attaching PP-57 compact digital microwave transmitter, Wireless Camera operation is available. Transmission distance is 1km(0.6mile) or more(depending on antenna configuration and environmental factors).

- * 7GHz Band or 10GHz Band transmission requires transmission licence from relevant authority.
- * PF-504 Microwave Receiver Unit is required.



Ikegami HDTV Tapeless Network Solution (Translation omitted)

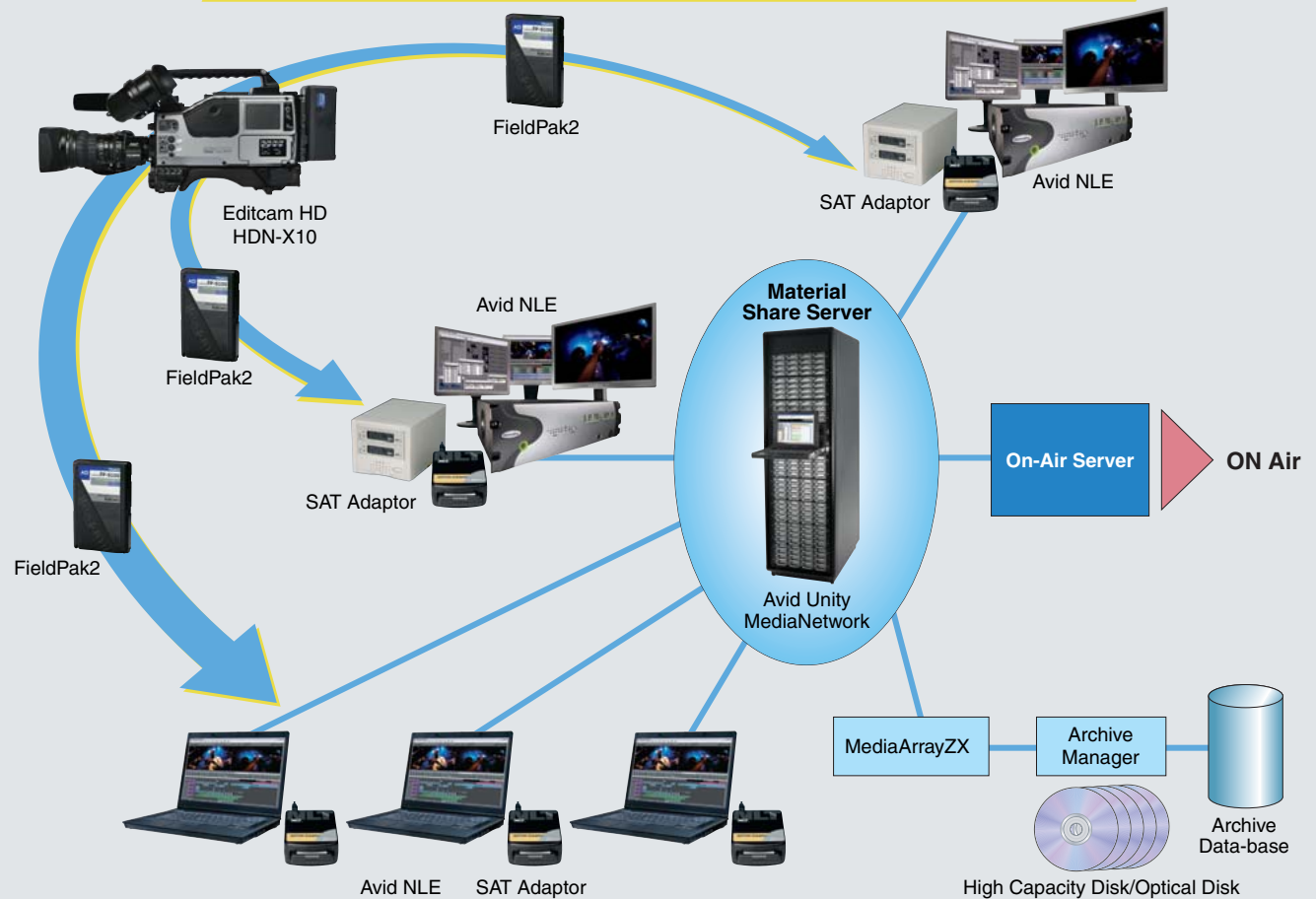

User-Conscious Features *(Translation omitted)*

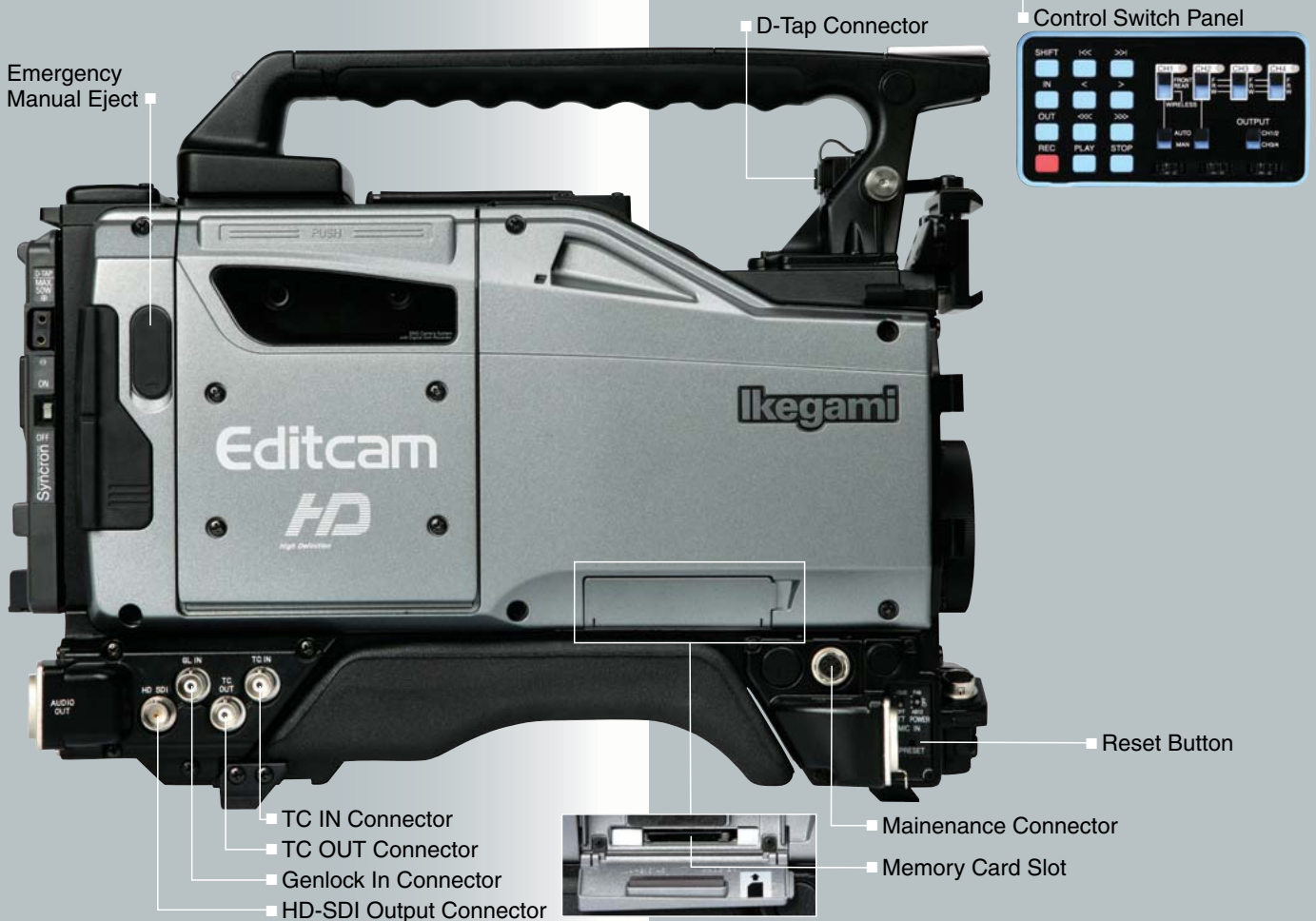
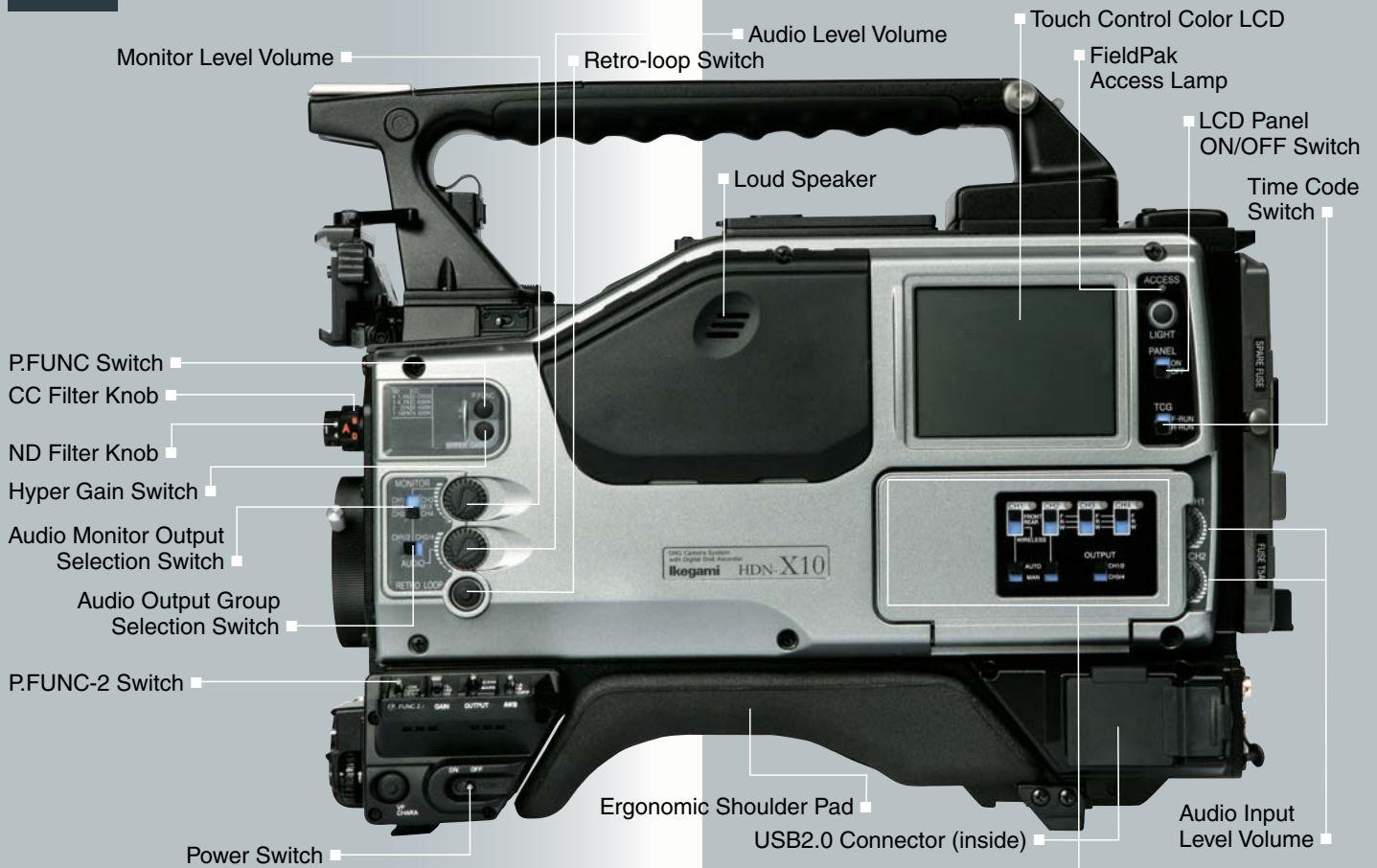

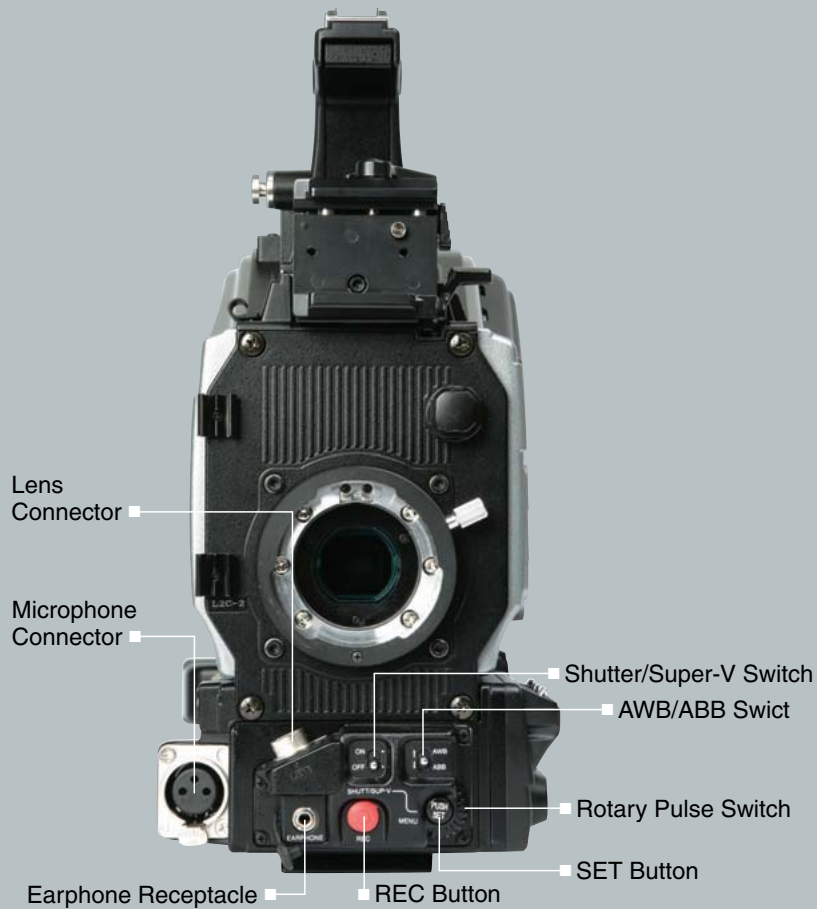

Removable Media



FieldPak2 (120GB)
Hard Disk Type

RAMPak (16GB)
Flash Memory Type

FieldPak Adaptor



SAT-200 (SCSI)

SAT-110 (USB2.0)

Proxy Board



PRX-DNS10

VTR Adaptor



VTA-207V

HD Fiber Optics Transmission System



Camera Fiber Adaptor for
HDTV Camera/Recorder
FE-C100A



Base Station
FE-B100A

Remote Control Unit



RM-50

HDTV Tapeless Camera/Recorder HDN-X10

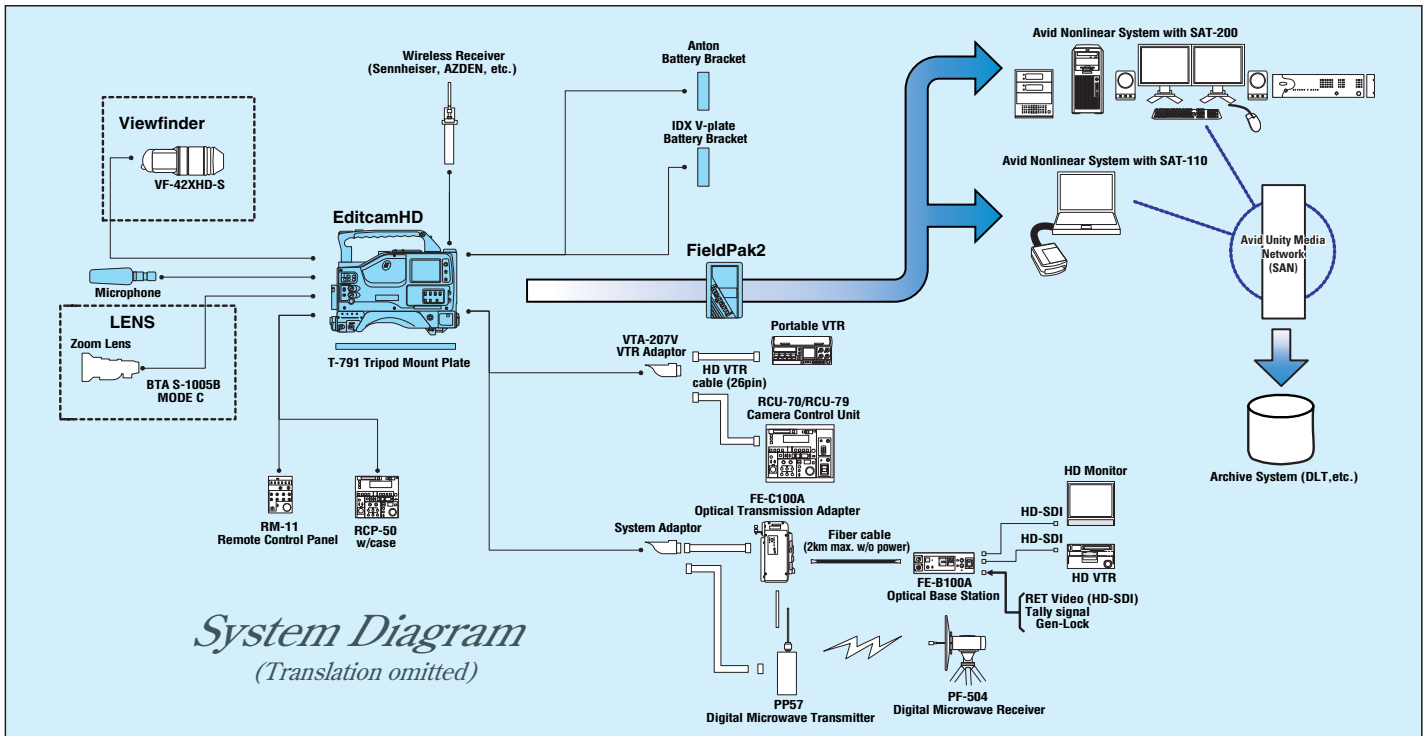

Rating/Performance

< Rating >

Scanning System 1080 lines 59.94Hz 2:1 interlaced 1920(H)X1080(V)
 720 lines 59.94Hz 1:1 non-interlaced 1280(H)X720(V)
 1080 lines 23.98Hz 1:1 non-interlaced 1920(H)X1080(V)
 1080 lines 50Hz 2:1 interlaced 1920(H)X1080(V)
 720 lines 50Hz 1:1 non-interlaced 1280(H)X720(V)

Image sensor 2/3-inch, 2,500,000-pixel CMOS Sensor

Optical System 2/3-inch, R,G,B prism optics

Sensitivity F8 / 2000 lx

Lens Mount BTA-S1005B

Optical Filter

	1	2	3	4
ND	100%	25%	6.2%	1.5%
CC	3200K	4300K	6300K	CROSS

Viewfinder 2-inch B/W Viewfinder

Operating Voltage +10VDC to +16VDC

Operating Temperature 0°C~40°C

Humidity (32°F~104°F)

Humidity 15% to 80% (Non-condensing)

EMI Compliance FCC Class-A, CE Class-A

Dimensions W138.5XH250.5XD320 mm
(W5.45XH9.9XD12.6 inches)

Weight approx. 4.5kg (10.0 lbs)

< Performance >

S/N 54dB
 Resolution/ Modulation Depth 1000TVL/45% or more (1080/59.94i 800TVL, 27.5MHz)
 700TVL/40% or more (720/59.94p 560TVL, 28.875MHz)
 1000TVL/45% or more (1080/23.98p 800TVL, 27.5MHz)
 1000TVL/45% or more (1080/50i 800TVL, 27.5MHz)
 700TVL/40% or more (720/50p 560TVL, 28.875MHz)
 Registration error 0.02% or less (without lens)
 Power consumption Camera Head: approx. 40W
 2-inch Viewfinder: approx. 6W

< Input Signals >

Audio signal 2ch XLR-3pin (0dBu/-40dBu/-60dBu)
 Microphone XLR-3pin (-40dBu/-60dBu), XLR-5pin: Factory Option
 Timecode BNC, SMPTE-12M-1995
 Genlock SMPTE-274M, SMPTE-296M (shared with SDTV)

< Output Signals >

HD-SDI signal BTA-S004B, SMPTE-292M
 Monitor signal Y(BNC connector, 75Ω) or SDTV VBS selectable
 VCR signal BTA-S1005B (Optimal VTA-207V required)
 Audio Signal XLR-5pin(0dBu)
 Earphone 2ch 3.5mm stereo jack
 USB connector 2-port USB2.0
 Genlock SMPTE-274M, SMPTE-296M (shared with SDTV)

< Recording Section >

Video Signal 1080/59.94i, 720/60p, 1080/23.98p, 1080/50i, 720/50p
 Video Compression Avid DNxHD 145Mbps
 (Avid DNxHD 220Mbps will be supported in the future)
 Typical Recording Time approx. 108 minutes
 (120GB FieldPak2 at 1080/59.94i)
 Audio Sampling Rate 16-bit, 48KHz or 44.1KHz selectable

•Product names and company names mentioned in this catalogue are trademarks and /or registered trademarks of their respective companies.
 •Editcam is registered trademark of Ikegami Tsushinki Co.,LTD..

Design and specifications are subject to change without notice.

H130A073-SI-F1 Printed in Japan

Ikegami IKEGAMI ELECTRONICS (U.S.A.), INC. ■URL <http://www.ikegami.com>

HEADQUARTERS 37 BROOK AVENUE, MAYWOOD, NJ 07607
 Phone:(201)368-9171 Fax:(201)569-1626

WEST COAST OFFICE 2631 MANHATTAN BEACH BLVD., REDONDO BEACH, CA 90278 Phone:(310)297-1900 Fax:(310)536-9550

SOUTHWEST OFFICE 773 BEARDEN WAXAHACHIE, TX 75167 Phone:(972)869-2363 Fax:(972)556-1057

MIDWEST OFFICE 747 CHURCH ROAD, UNIT C1, ELMHURST, IL 60126 Phone:(630) 834-9774 Fax:(630)834-8689

SOUTHEAST OFFICE 5200 N.W. 33RD AVENUE, SUITE 111 FORT LAUDERDALE, FL 33309 Phone:(954)735-2203 Fax:(954) 735-2227

