

Ikegami

DNE-31

Editcam Station 2

Portable Nonlinear Disk Recorder



The DNE-31 Non-Linear Recorder is a high performance, intelligent digital recorder that uses the industry proven, removable FieldPak as the non-linear media.

The DNE-31 records in OMF file format and a number of Avid Compressions (JFIF, DV25, DV50, IMX). Media recorded using the DNE-31's FieldPak can be immediately edited, without any transfer, by any Avid Nonlinear Editing System.

In addition, Avid Muticam Resolution can be selected, facilitating near instant multiple camera off-line editing.

Composite video, SDI, and 4-channel analog audio are available as record and playback sources for the DNE-31. Using an external remote controller, Jog/Shuttle operations can be used for locating clips.

- The DNE-31 records on the same FieldPaks used by Ikegami disk cameras
- Universal Avid Nonlinear Editing Compatibility: JFIF (Avid Meridian) and DV25; DV50 and IMX (optional)
- Advanced non-linear features: RetroLoop, Time Lapse, Intelligent Recording
- Two removable 20GB FieldPaks provide 3 hours of DV25 recording
- 9-pin RS422 remote and 100 Mbps Ethernet interfaces

Compatibility

By using the Native AVID OMF File Format all Avid Nonlinear Editing systems can directly edit the media recorded on the FieldPak. This provides instant access to media without any costly transfer or digitizing time.

Avid Multicam Resolution support

Allows editing synchronized clips from multiple DNE-31 recorders in multiple split viewing. Multicam editing provides powerful time savings in the off-line editing process.

FieldPak removable non-linear media

Uses the industry proven FieldPak, a highly reliable removable HDD which is also used by the Editcam disk camcorders.

Compression Formats

Industry proven compression formats: DV25, JFIF3:1, 10:1, 20:1, 4:1s, 15:1s, and Multicam. Optionally the DNE-31 supports DV50 and IMX.

Remote Control

The DNE-31 can be controlled using the optional SRC-11 external RS422 controller, providing shuttle search for clips.

DNE-31 Models

The following 3 models of the DNE-31 are available:

- A-Version.....JFIF and DV25
 - B-Version.....JFIF and DV25/50(*)
 - C-Version.....JFIF, DV25, DV50, and IMX
- *field upgradeable to C-Version



SRC-11 Remote Controller

Specifications

Video System	NTSC, PAL Switchable
Recording Format	DV
	DV25-NTSC 4:1:1
	DV25-PAL 4:2:0
	DV25-PAL 4:1:1
JFIF	3:1, 10:1, 20:1, 4:1s, 15:1s, Multicam
MPEG2	IMX (MPEG50)
Video Input	
SDI	BNC, SMPTE259M, 270Mb/s
Composite Video	BNC, Negative sync, 1Vp-p, 75ohm
Reference	BNC, negative sync, 1Vp-p, 75ohm
Video Output	
SDI	2 BNC outputs, SMPTE259M, 270Mb/s
Composite Video(PVW)	BNC, negative sync, 1Vp-p, 75ohm
Composite Video(PGM)	BNC, negative sync, 1Vp-p, 75ohm
Reference	BNC, negative sync, 1Vp-p, 75ohm
Audio Input	
Analog Audio	4ch XLR, High impedance, balanced
LTC	BNC, 0.5-18Vp-p, unbalanced
Audio Output	
Analog Audio	4ch XLR, Low impedance, balanced
Speaker/Headphone	Front Panel/1/4in Stereo Phone Jack
LTC	BNC, 0.5-18Vp-p, unbalanced
Other Interfaces:	
RS232	D-Sub 9 pin
RS422	D-Sub 9 pin
Ethernet	RJ45, 10/100Mbps
Power Requirements	AC100-220V, 60/50Hz
Weight	4.5Kg (9.9lb)
Dimensions	222 (W) X175 (H) X377 (D) mm
	8.74 (W) X6.89 (H) X14.84 (D) inches

Rear Panel



System Diagram

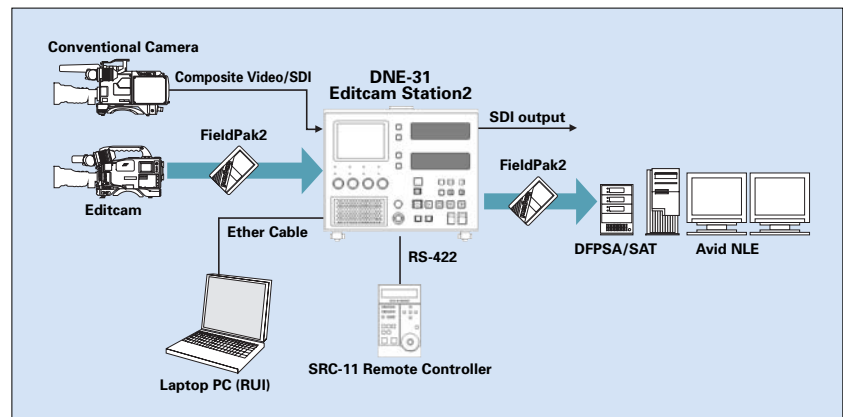

FieldPak is a registered trademark of Avid Technology Inc.
 IMX is a registered trademark of Sony Corporation.
 Editcam is a registered trademark of Ikegami Electronics(U.S.A) Inc.

Design and specifications are subject to change without notice.

I191B063-SI-F1 Printed in Japan

Ikegami IKEGAMI ELECTRONICS (U.S.A.), INC.

■ URL <http://www.ikegami.com>

HEADQUARTERS 37 BROOK AVENUE, MAYWOOD, NJ 07607
 Phone:(201)368-9171 Fax:(201)569-1626

WEST COAST OFFICE 2631 MANHATTAN BEACH BLVD., REDONDO BEACH, CA 90278 Phone:(310)297-1900 Fax:(310)536-9550

SOUTHWEST OFFICE 773 BEARDEN WAXAHACHIE, TX 75167 Phone:(972)869-2363 Fax:(972)556-1057

MIDWEST OFFICE 747 CHURCH ROAD, UNIT C1, ELMHURST, IL 60126 Phone:(630) 834-9774 Fax:(630)834-8689

SOUTHEAST OFFICE 5200 N.W. 33RD AVENUE, SUITE 111 FORT LAUDERDALE, FL 33309 Phone:(954)735-2203 Fax:(954) 735-2227

