



Pre-Assembled Hyper Dynamic Elevator Color Camera

PAC-A11E-25



The PAC-A11E-25 is a wide dynamic color camera assembled in the a mini-sized sheet steel housing with vandal resistant polycarbonate glass to use in the elevator or the transit applications.

Features

- Ikegami Hyper Dynamic Camera ISD-A11 built-in
- 2.5mm Wide Angle Lens built-in
- Indoor Installation
- Sheet Steel construction (3mm thick)
- Vandal Resistant Polycarbonate Glass
- Epoxy Painted
- Vandal Resistant Screws
- 113(W) x 155(H) x 158(D)mm
- Power DC12V (Optional AC24V-DC12V adaptor is available)

Ikegami PAC-A11E-25 Hyper Dynamic Elevator Camera

Specifications:

[Camera]

Image Sensor: 1/3" Pixim DPS Sensor
Pixel Number: Approx. 390,000 pixels
Video Output: NTSC/PAL composite video,
VBS 1.0Vp-p 75ohm
Scanning System: NTSC 525lines, 60Hz, 2:1 Interlaced
PAL 625lines, 50Hz, 2:1 Interlaced
Sync System: Internal lock (Crystal controlled)
Horizontal Resolution: Minimum 480TV lines
S/N Ratio: 50dB or better in normal mode
(AGC off, DTL off)
Minimum Illumination: 2.0 Lux at F2.0
White Balance: ATW full time auto tracking white balance
Digital Noise Reduction: Built-in
Power Requirement: DC12V (Optional AC24V-DC12V adaptor)
Dimensions: 40mm x 40mm x 44.5mm (WHD)

[Lens]

IK-V-4402.5-2.5-HR-FT 2.5mm F2.0

[Housing]

General: Sheet Steel 3mm thick
Epoxy polyester Powder Painting
Vandal Resistant Polycarbonate Glass
External Dimensions: 113 x 155 x 158mm (WHD)
Window Dimensions: 68 - 48x50mm
Vandal Proof Screw Lock: Provided



External Drawings:

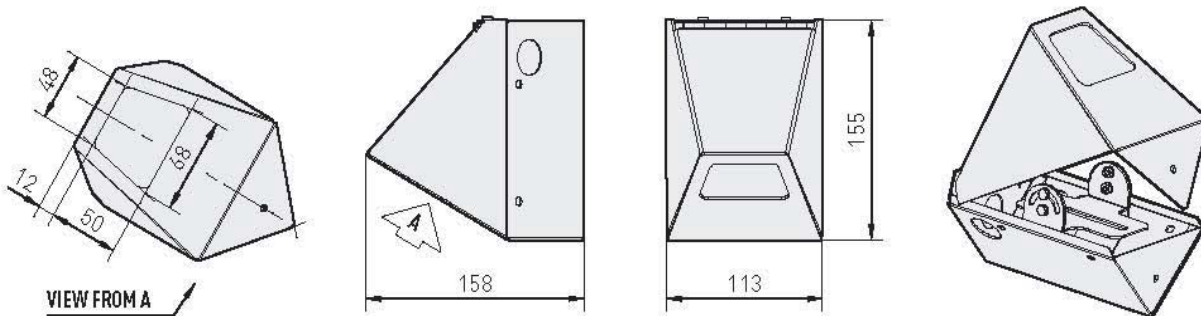

Design and specifications are subject to change without notice.

Ikegami

IKEGAMI ELECTRONICS (U.S.A.), INC.

URL <http://www.ikegami.com>

08262008-TH-CCTV-0001

**HEADQUARTERS
WESTCOAST OFFICE**

37 Brook Avenue, Maywood, NJ 07607 Phone (201)368-9171 Fax (201)569-1626
2631 Manhattan Beach Blvd., Redondo Beach, CA 90278
Phone (310)297-1900 Fax (310)536-9550

**SOUTHWEST OFFICE
MIDWEST OFFICE
SOUTHEAST OFFICE**

773 Bearden Road, Waxahachie, TX 75167 Phone (972)869-2363 Fax (972)556-1057
747 Church Road, Unit C1, Elmhurst, IL 60126 Phone (630)834-9774 Fax (630)834-8689
5200 N.W. 33rd Avenue, Suite 111, Fort Lauderdale, FL 33309
Phone (954)735-2203 Fax (954)735-2227