

Ikegami

INSTRUCTION MANUAL

MODEL ICD-36

B/W CCD CAMERA

OUTDOOR USE WARNING

WARNING — TO PREVENT FIRE OR ELECTRIC SHOCK, DO NOT EXPOSE THIS APPLIANCE TO RAIN OR MOISTURE.

Thank you very much for your wise choice of the Ikegami Black & White CCD Camera. Please carefully read this Instruction Manual to keep your camera at full capacity.

Contents

	Page
1. General	1
2. Features	1
3. Handling precautions	1
4. Names of Parts and their functions	2
5. Connection	5
5-1. Auto iris lens connector	5
5-2. Video output connector (VIDEO OUT)	6
5-3. Power connection	6
6. Lens adjustment	8
6-1. Lens adjustment	8
6-2. Flange focal distance adjustment	9
7. User Setting	10
7-1. LL (Line Lock) - INT (Internal) selector switch	10
7-2. Auto electronic shutter (AES) selector switch	10
7-3. Backlight compensation (BLC)	11
7-4. Automatic gain control (AGC)	11
8. Specifications	12
9. Appearance view	

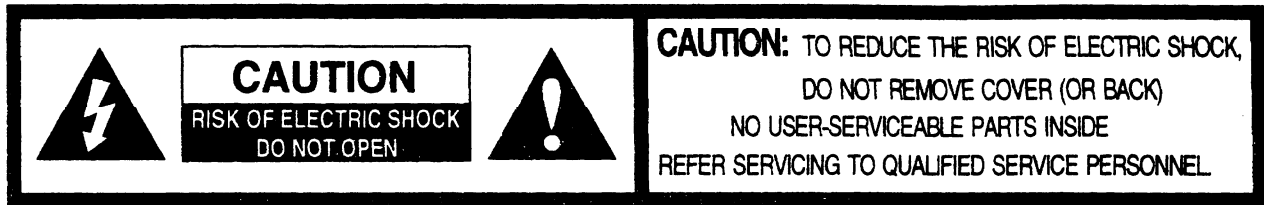

The lightning flash with arrowhead symbol, within an equilateral triangle, is intended to alert the user to the presence of uninsulated "dangerous voltage" within the product's enclosure that may be of sufficient magnitude to constitute a risk of electric shock to persons.



The exclamation point within an equilateral triangle is intended to alert the user to the presence of important operating and maintenance (servicing) instructions in the literature accompanying the appliance.

This device complies with Part 15 of the FCC Rules. Operation is subject to the following two conditions: (1) this device may not cause harmful interference, and (2) this device must accept any interference received, including interference that may cause undesired operation.

CAUTION:

ANY CHANGES OR MODIFICATIONS NOT EXPRESSLY APPROVED BY THE PART RESPONSIBLE FOR COMPLIANCE COULD VOID THE USERS AUTHORITY TO OPERATE THE EQUIPMENT.

IMPORTANT SAFEGUARDS

- **Read Instructions** – All the safety and operating instructions should be read before the appliance is operated.
- **Retain Instructions** – The safety and operating instructions should be retained for future reference.
- **Heed Warnings** – All warnings on the appliance and in the operating instructions should be adhered to.
- **Follow Instructions** – All operating and use instructions should be followed.
- **Cleaning** – Unplug this video product from the wall outlet before cleaning. Do not use liquid cleaners or aerosol cleaners. Use a damp cloth for cleaning.
- **Attachments** – Do not use attachments not recommended by the video product manufactures as they may cause hazards.
- **Water and Moisture** – Do not use this video product near water – for example, near a bath tub, wash bowl, kitchen sink, or laundry tub, in a wet basement, or near a swimming pool, and the like.
- **Accessories** – Do not place this video product on an unstable cart, stand, tripod, bracket, or table. The video product may fall, causing serious injury to person, and serious damage to the appliance. Use only with a cart, stand, tripod, bracket, or table recommended by the manufacturer, or sold with the video product. Any mounting of the appliance should follow the manufacturer's instructions, and should use a mounting accessory recommended by the manufacturer.
- **Power Sources** – This video product should be operated only from the type of power source indicated on the marking label. If you are not sure of the type of power supply to your home, consult your appliance dealer or local power company. For video products intended to operate from battery power, or other sources, refer to the operating instructions.
- **Grounding or Polarization** – This video product is equipped with a polarized alternating current line-plug (a plug having one blade wider than the other) or a 3-wire grounding-type plug (a plug having a third grounding pin). This is a safety feature. The plug having one blade wider than the other will fit into the power outlet only one way. If you are unable to insert the plug fully into the outlet, try reversing the plug. The plug having a third grounding pin will only fit into a grounding-type power outlet. If the plug should fail to fit, contact you electrician to replace your obsolete outlet. Do not defeat the safety purpose of the polarized plug or the grounding-type plug.
- **Power-Cord Protection** – Power-supply cords should be routed so that they are not likely to be walked on or pinched by items placed upon or against them, paying particular attention to cords at plugs, convenience receptacles, and the point where they exit from the appliance.
- **Lightning** – For added protection for this video product receiver during a lightning storm, or when it is left unattended and unused for long periods of time, unplug it from the wall outlet and disconnect the cable system.

This will prevent damage to the video product due to lightning and power-line surges.

- **Power Lines** – An outside antenna system should not be located in the vicinity of overhead power lines or other electric light or power circuits, or where it can fall into such power lines or circuits. When installing an outside antenna system, extreme care should be taken to keep from touching such power lines or circuits as contact with them might be fatal.
- **Overloading** – Do not overload wall outlets and extension cords as this can result in a risk of fire or electric shock.
- **Object and Liquid Entry** – Never push objects of any kind into this video product through openings as they may touch dangerous voltage points or short-out parts that could result in a fire or electric shock. Never spill liquid of any kind on the video product.
- **Servicing** – Do not attempt to service this video product yourself as opening or removing covers may expose you to dangerous voltage or other hazards. Refer all servicing to qualified service personnel.
- **Damage Requiring Service** – Unplug this video product from the wall outlet and refer servicing to qualified service personnel under the following conditions:
 - a. When the power-supply cord or plug is damaged.
 - b. If liquid has been spilled, or objects have fallen into the video product.
 - c. If the video product has been exposed to rain or water.
 - d. If the video product does not operate normally by following the operating instructions. Adjust only those controls that are covered by the operating instructions as an improper adjustment of other controls may result in damage and will often require extensive work by a qualified technician to restore the video product to its normal operation.
 - e. If the video product has been dropped or the cabinet has been damaged.
 - f. When the video product exhibits a distinct change in performance – this indicates a need for service.
- **Replacement Parts** – When replacement parts are required, be sure the service technician has used replacement parts specified by the manufacturer or have the same characteristics as the original part. Unauthorized substitutions may result in fire, electric shock or other hazards.
- **Safety Check** – Upon completion of any service or repairs to this video product, ask the service technician to perform safety checks to determine that the video product is in proper operating condition.

1. General

The ICD-36 is a black & white monitor camera with a 1/3" CCD (charge-coupled device). This unit is equipped with line lock, auto electronic shutter (AES), backlight compensation (BLC), two-way auto iris and other functions. Designed for the high horizontal resolution of 570 lines and the minimum illuminance of 0.2 lux, the high-sensitivity camera is best suited for general monitoring applications.

2. Features

(1) High sensitivity/high resolution

The camera has a 380,000-pixel high-sensitivity CCD with an on-chip micro-lens, as well as a high-performance AGC circuitry. These components enable a horizontal resolution as high as 570 lines and a sensitivity so high to catch images under the minimum subject illuminance of 0.2 lux/F1.4.

(2) Automatic electronic shutter (AES)

The camera is provided with the wide-range automatic sensitivity adjustment function using a high-speed electronic shutter. Even with a fixed-iris lens, the camera can give stable video output that is as good as an auto iris lens in the F1.4 to F40 range.

(3) Backlight compensation (BLC)

In combination with the AES function or an auto iris lens, the backlight compensation circuit helps shoot crisp images on a backlight scene.

(4) Two-way auto iris function

Thanks to the selector switch for video iris lenses and DC iris lenses, almost all types of CCTV auto iris lenses can be used on this camera.

(5) Flange focal distance adjustment

The flange focal distance adjuster makes it easy to adjust the focus tracking with a zoom lens in use.

3. Handling precautions

- (1) Do not open the camera housing. The precision parts inside may get affected and damaged.
- (2) Do not use the camera in any water-splashed or humid place. Make sure the ambient temperatures are within the range of -5 to $+40$ °C.
- (3) When moving and setting up the camera, be careful not to drop or hit it.
- (4) Never touch the CCD face plate with hands.

4. Names of Parts and their functions

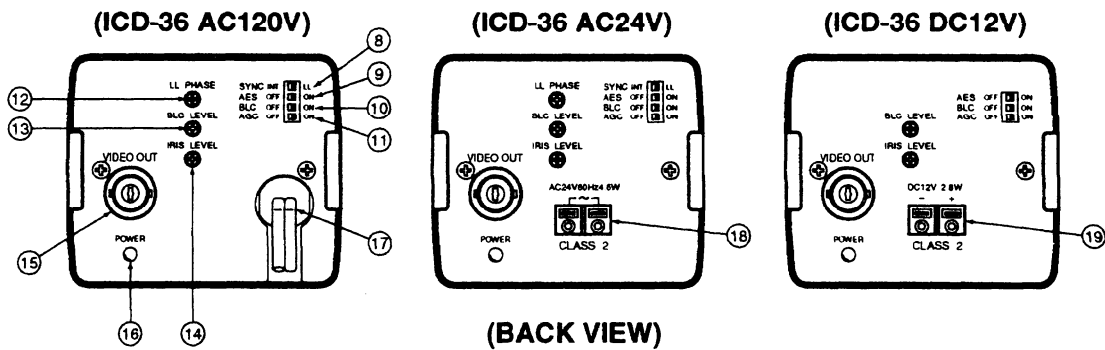
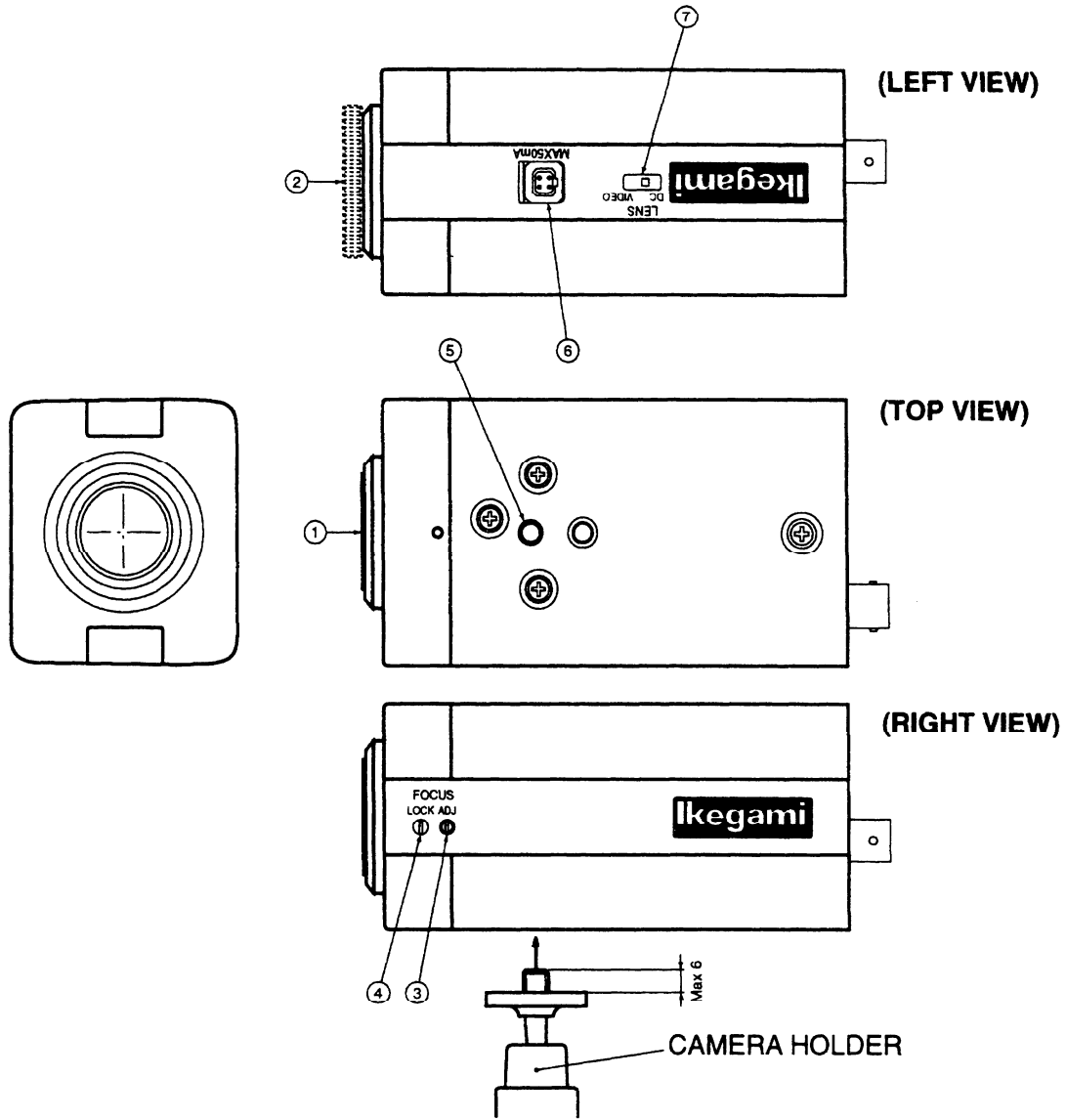

- ① **Lens mount (CS mount)**
Used to mount the lens. Various types of CS mount lenses are applicable.
- ② **C mount adaptor (option)**
Attachable on the lens mount in order to accept various types of C mount lenses.
- ③ **Flange focal distance adjuster**
Used to adjust the flange focal distance depending on the lens used. Helpful if the lens' focus ring fails to put into focus.
- ④ **Flange focal distance lock screw**
Used to mechanically fix the camera's flange focal distance after its fine adjustment.
- ⑤ **Holder screw hole**
Used to mount the camera onto the camera holder.
Effective for general camera tripods.

Note:

Make sure the tripod and camera holder mounting screw (1/4"-20UNC) is 6 mm or shorter.

- ⑥ **Auto iris lens connector**
Specifically used to connect an auto iris lens.
- ⑦ **Lens selector switch**
Used to choose between the video iris lens and the DC iris lens depending on the type of an auto iris lens in use.
- ⑧ **Sync system selector switch (SYNC)**
Used to select the line lock (LL) or internal crystal lock (INT).
- ⑨ **AES selector switch (AES)**
Used to turn on and off the AES function.

Note:

With an auto iris lens in use, be sure to keep the switch at the OFF position.

- ⑩ **Backlight compensation selector switch (BLC)**
Used to turn on and off the backlight compensation function.
- ⑪ **AGC selector switch (AGC)**
Used to turn on and off the AGC function.
- ⑫ **LL phase control (LL PHASE)**
Used to adjust the line lock phase.
- ⑬ **Backlight compensation control (BLC)**
Used to adjust the backlight compensation level with the BLC selector at the ON position.
- ⑭ **Iris level control**
Used to adjust the iris level with the DC lens in use.

- ⑮ **Video output terminal (VIDEO OUT)**
Used to give out the video signal. Connected to the video input terminal of a monitor, switcher, etc. (To be terminated with 75-ohm impedance)
- ⑯ **Power indicator (POWER)**
Lights up in green when the power is supplied to the camera.
- ⑰ **AC 120V power cable**
Used to supply AC 120V power. AC 108-132V power is acceptable.
- ⑱ **AC 24V power input terminal**
Used to receive AC 19.6-26.4V power.
- ⑲ **DC 12V power input terminal**
Used to receive DC 10.5-15V power.

5. Connection

5-1. Auto iris lens connector

Use the auto iris lens connector plug. (E4-191J-100 or equivalent)

- **For the video type auto iris lens**

Set the lens selector switch to VIDEO position.

— Connector cable leads —

1. Red (power)
2. Not used
3. White (video)
4. Black (shielded)

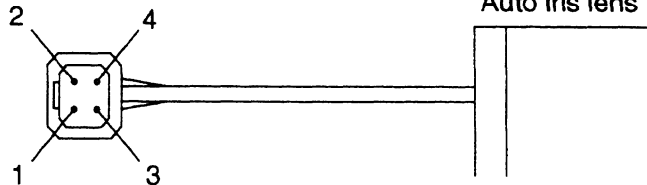

* Dress the tip of the green lead to prevent a short-circuit.

- **For the DC type auto iris lens**

Set the lens selector switch to the DC position.

— Connector cable leads —

1. Damping coil (-)
2. Damping coil (+)
3. Driving coil (+)
4. Driving coil (-)

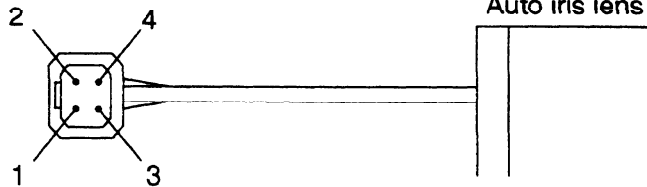

* Connect the leads as shown above. Refer also to the instructions of the lens.

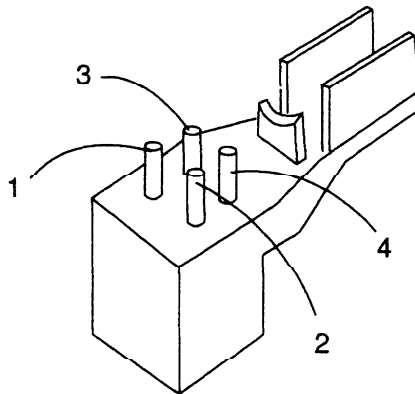

Numbers of connector pins

5-2. Video output connector (VIDEO OUT)

- This connector is used to give out the video signal.
- Connect the camera to the video input connector of a monitor, switcher or other equipment. (Connected with 75-ohm impedance.)
- Use a coaxial cable for connections.

(Connection example)

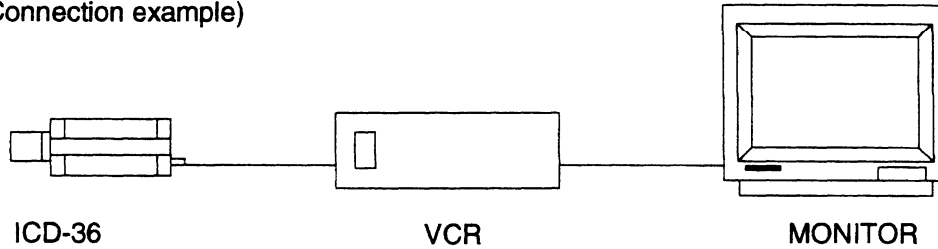

5-3. Power connection

- AC 120V type
Plug the camera's power cable in an AC 120V ($\pm 10\%$) power outlet.

Note:

The camera has no power switch. Just plug in the power cable and the camera gets started. To turn off the camera, just unplug the power cable.

- AC 24V type
AC24V60Hz 4.6W This installation should be made by a qualified service person and should conform to all local codes.

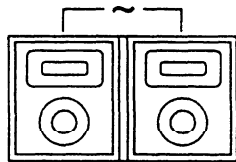

CLASS 2

AC 24V $\pm 10\%$ supply power

- DC 12V type

DC12V 2.8W

- +

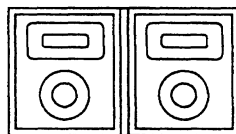

CLASS 2

Feed DC 10.5–15V power.

- * The positive (+) and negative (-) polarities do not matter. When connecting two or more cameras to a single power supply, however, keep their polarities in mind.

Notes:

- Before feeding the power, make sure all the necessary connections are complete.
- Turn on and off the power at the power supply unit.
- Connections to the power input terminal block

(1) Applicable wire size

- ① Solid conductor wire: 0.4-1.0 mm in diameter (AWG26-18)
- ② Flexible stranded conductor wire: AWG22-20

(2) Dressing the wire end

Peel off the sheath about 10 mm from the wire end. For the flexible stranded wire, twist the conductor enough.

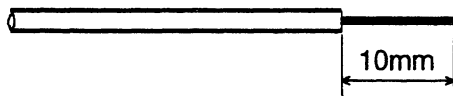

(3) Connecting and disconnecting

Be sure to turn off the power supply before connecting and disconnecting the wire.

① Connecting

- a. When the conductor is a solid wire 0.8-1.0 mm in diameter, just insert the wire end into the hole of the terminal block.
- b. For a thin solid wire or a flexible stranded wire, hold down the square key () on the terminal block using a small bladed screwdriver, and insert the wire into the hole.
- c. Finally pull the wire gently to make sure it is tight in position.

② Disconnecting

Hold down the square key () on the terminal block using a small bladed screwdriver and draw out the wire. If the wire is difficult to draw out, press the screwdriver against the key a little harder. Never force the wire out of the hole. Otherwise the wire might be broken.

6. Lens adjustment

6-1. Lens adjustment

- Video iris lens

The video iris lens has two adjusting controls: LEVEL and ALC. Take the following adjustment steps.

- (1) Turn the ALC control all the way to the Average position.
- (2) Shoot a scene in which the brightness-to-darkness (white-to-black) ratio is 50-50. Adjust the lens' LEVEL control so that the video level of the bright zone be 0.7 Vp-p. Be careful not to shoot too dark a scene because otherwise satisfactory adjustment cannot be expected.
- (3) Shoot your target scene and adjust the lens' ALC control to get the best brightness level. If the ratio in brightness is too high in the scene, the ALC control does not work; in other words, the tone on the screen hardly changes.

- DC iris lens

When the DC iris lens is used, adjust the IRIS LEVEL control on the camera.

- (1) Shoot a scene in which the brightness-to-darkness (white-to-black) ratio is 50-50. Adjust the camera's IRIS LEVEL control so that the video level of the bright zone be 0.7 Vp-p. Be careful not to shoot too dark a scene because otherwise satisfactory adjustment cannot be expected.

- Manual lens

- (1) With the AES selector at ON position

Usually keep the lens iris open. But some types of lenses may have poor openness characteristic. It is therefore advisable to make two turns back from the open position.

- (2) With the AES selector at OFF position

Adjust the lens iris according to the brightness of a subject.

6-2. Flange focal distance adjustment

The flange focal distance is a distance between the lens mounting face and the image formation point. This distance may have to be readjusted when a lens is mounted. If the lens' focus ring is not effective in adjusting the focus, use the camera's flange focal distance adjuster. See the figure below.

- * Finally tighten up the flange focal distance lock screw.

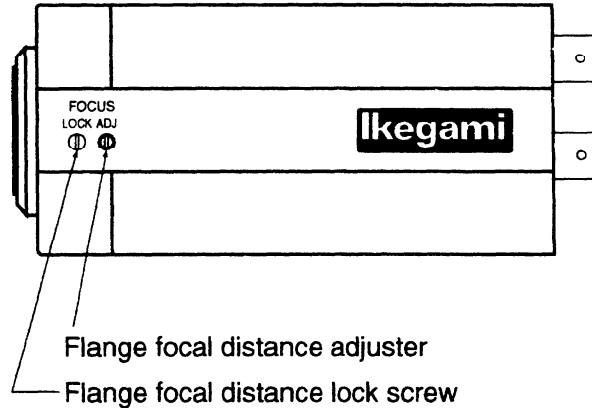

Notes:

- Both C mount lenses and CS mount lenses can be used on this camera. Attach the C mount adaptor (optional), however, depending on the type of lens used. See the table below.

Lens mount	Necessary/Unnecessary
C	Necessary
CS	Unnecessary

- The dimension "L" at the lens mount (as shown at right) must be shorter than 10 mm for the C mount lens and shorter than 5 mm for the CS mount lens. If longer than specified, the lens may be mal-positioned or the camera itself may be damaged.

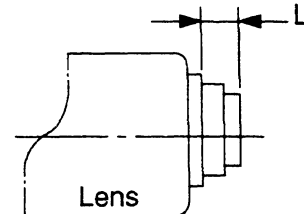

7. User setting

7-1. LL (Line Lock) - INT (Internal) selector switch

- LL (Line Lock) position
The video output gets in sync with the power line.

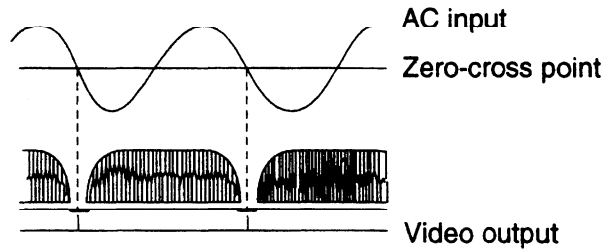

- * Using the LL PHASE control, the video output phase can be shifted $\pm 90^\circ$ with respect to the AC input line phase. See the above figure.
- * This type of sync helps eliminate the so-called image peel-off phenomenon which would happen when two or more cameras are switched each other with a switcher, for example.
- INT (Internal Crystal Lock) position
The camera is put in the internal sync mode.

7-2. Auto electronic shutter (AES) selector switch

The AES selector switch is used to turn on and off the automatic electronic shutter (AES) function of the camera.

- ON: In the AES mode
The high-speed electronic shutter is used for automatic sensitivity control function. Proper video output is guaranteed even with a fixed-iris lens in use.
- OFF: In the normal mode
- * In the AES mode, such smear as shown at right may happen, which produces poor images on the screen. This is peculiar to CCD elements, but not a trouble. Switch off the AES function and use an auto iris lens to avoid such phenomenon.
- * Be sure to keep the AES function off when the auto iris lens is used.

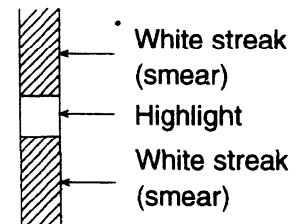

7-3. Backlight compensation (BLC)

When fairly bright light (outside a window for example) is behind a subject, the subject looks shadowy. In such a case, the backlight effect should be compensated.

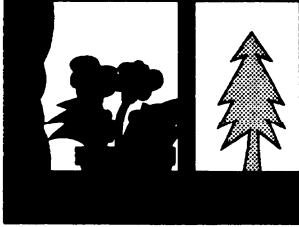

BLC-OFF

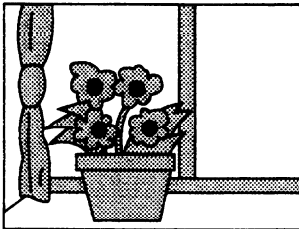

BLC-ON

- Typical backlight compensation

Let us look at the sketch at left. When shooting the house plant with the BLC switch off, the flowers will appear very dark because the background is very bright.

To make the flowers look bright, turn on the BLC switch and adjust the BLC LEVEL control to get an optimum image. In the sketch at left, the level is adjusted for the flowers at the window, but the view outside the window looks whitish.

- * The BLC function does not make a big difference when the entire scene is dark with no backlight.

- * Hunting may occur under certain shooting condition. In such a case, adjust the BLC LEVEL control to get rid of the hunting.

7-4. Automatic gain control (AGC)

- Usually keep the AGC switch at the ON position.
- Set the switch to the OFF position if noises (white spots) appear on a dark scene.

8. Specifications

- | | |
|---|---|
| (1) Imaging device: | 1/3 inch, IT-CCD
Effective pixels: 768(H) x 494(V), about 380,000 pixels |
| (2) Scanning system: | 525 lines at 60 Hz, 2:1 interlace |
| (3) Sync system: | Internal sync and line lock (phase adjustable) |
| (4) Scanning frequency: | Horizontal: 15.75 kHz
Vertical: 60 Hz |
| (5) Video output: | VS 1.0 Vp-p at 75 ohms |
| (6) Resolution: | Horizontal: 570 lines
Vertical: 350 lines |
| (7) Signal-to-noise ratio: | Over 46 dB (AGC off, DETAIL off, weighted) |
| (8) Subject illuminance
(light source: tungsten lamp,
colour temperature: 2856K): | ① Standard illuminance: About 18 lux/F1.4
② Minimum illuminance: 0.2 lux/F1.4 |
| (9) AGC (Automatic gain control): | ON/OFF switchable |
| (10) Gamma correction: | Fixed at about 0.45 |
| (11) White peak clipper: | Provided |
| (12) AES function: | Provided (ON/OFF switchable)
AES range: About 1 : 800 (within the visible rays range) |
| (13) Backlight compensation function: | Provided (ON/OFF, level adjustable) |
| (14) Auto iris function: | Compatible with video iris and DC iris (selectable)
(With DC iris level adjuster) |
| (15) Lens mount: | CS mount (C mount adaptor optionally available) |
| (16) Flange focal distance adjuster: | Provided |
| (17) Camera mount: | 1/4"-20UNC (top and bottom mounting) |
| (18) Supply power: | ① AC 120V +10%, 60 Hz
② AC 24V +10%, 60 Hz
③ DC 12V (10.5-15V) |
| (19) Power consumption: | ① AC 120V type: 4.8W approx.
② AC 24V type: 4.6W approx.
③ DC 12V type: 2.8W approx. |
| (20) Ambient operating temperature/humidity: | -10 to +50°C, 30-85%RH (no condensation) |
| (21) Outer dimensions: | 70(W) x 60(H) x 125(D) mm (without projections and accessories) |
| (22) Weight: | ① AC 120V type: 850 g approx.
② AC 24V type: 750 g approx.
③ DC 12V type: 550 g approx. |

(23) Input/output connectors:

① Video output: BNC

② Lens control: 4P (compatible plug E4-191J-100 or equivalent)

③ AC 24V/DC 12V input: 2P terminal block

(24) Accessories:

① Instruction Manual, 1 copy

(25) Option:

C mount adaptor: C-AD2

Lens connector plug: E4-191J-100

9. Appearance view

• ICD-36 AC 120V

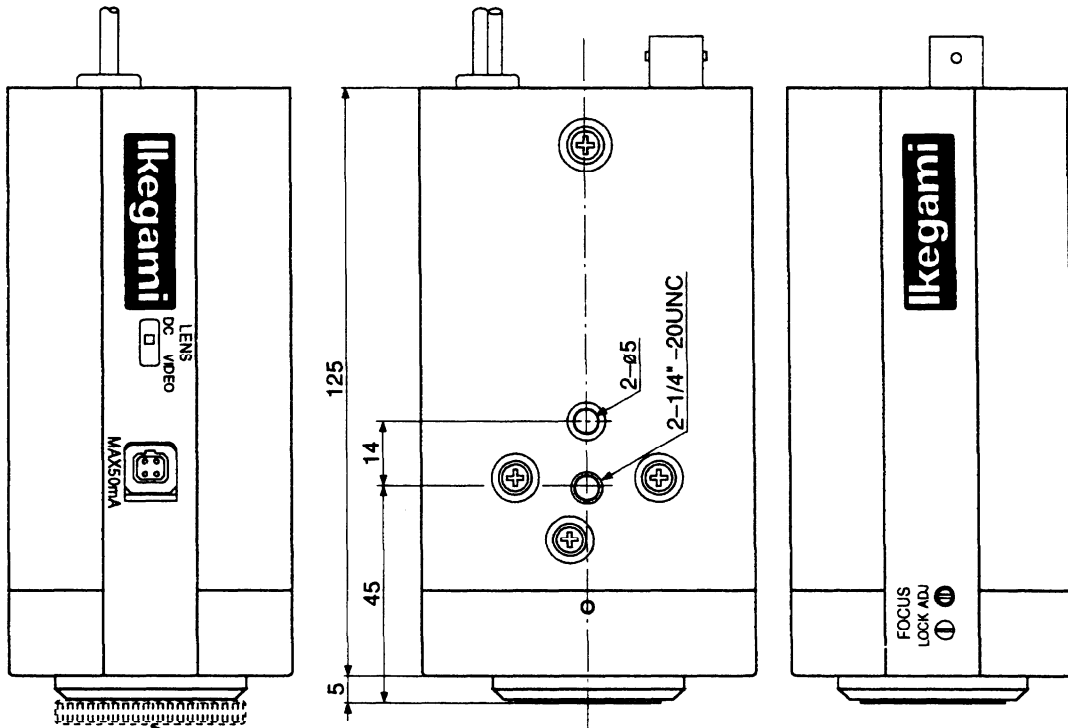
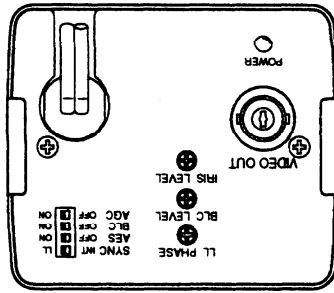

C MOUNT ADAPTOR
(OPTION)

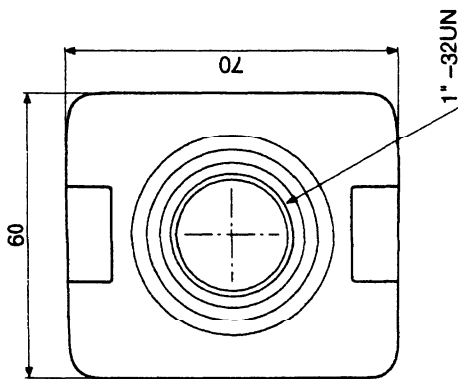

• ICD-36 AC 24V

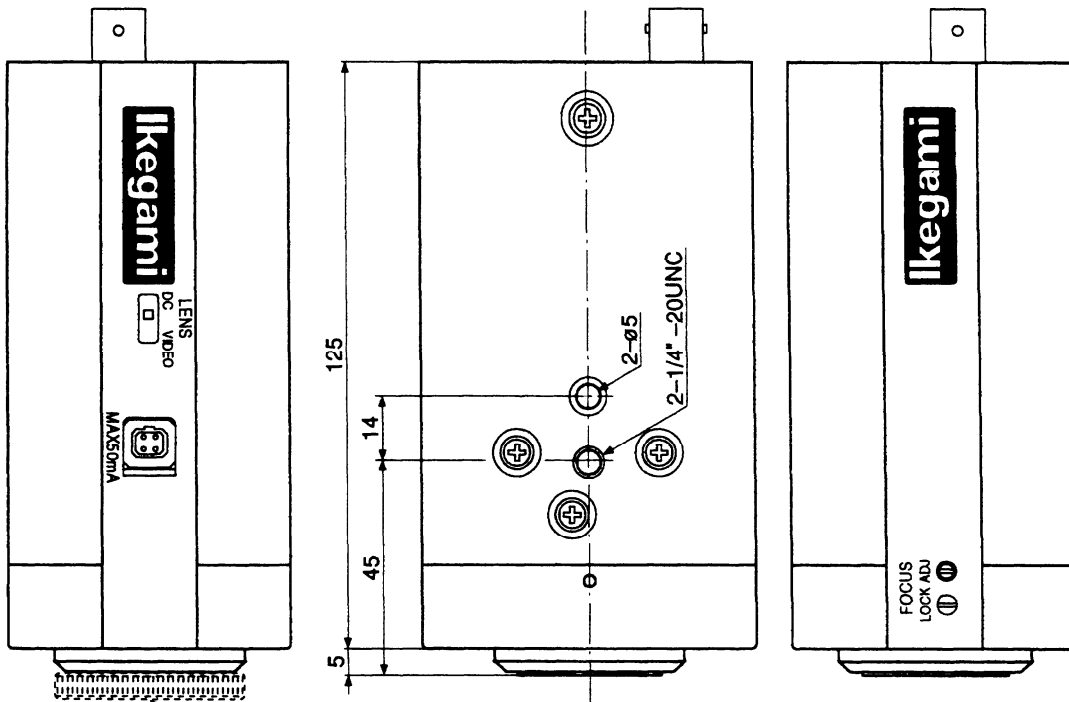
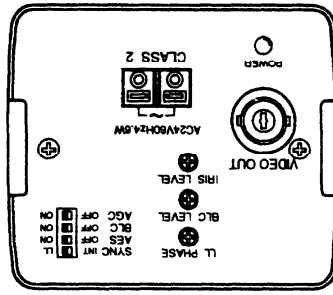

C MOUNT ADAPTOR
(OPTION)

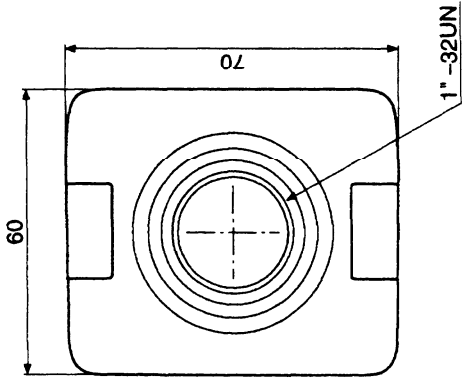

• ICD-36 DC 12V

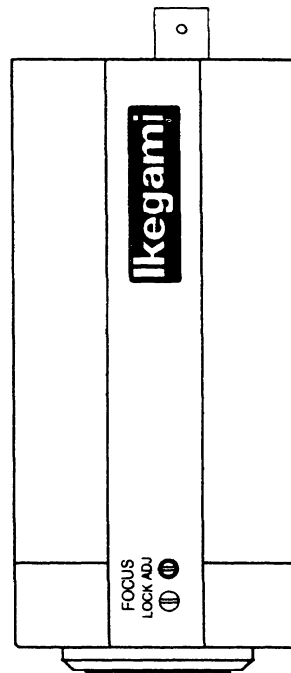
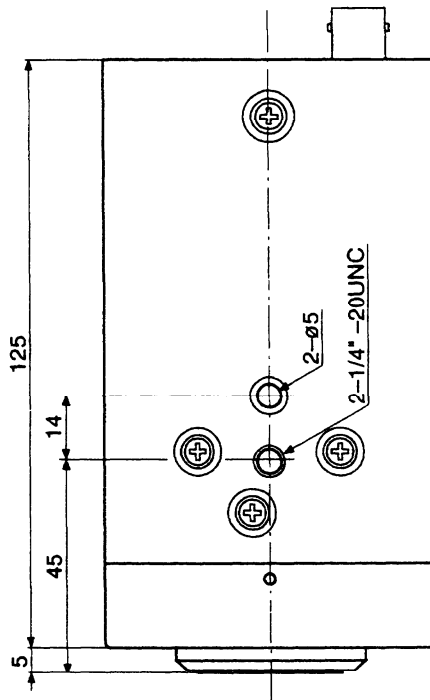
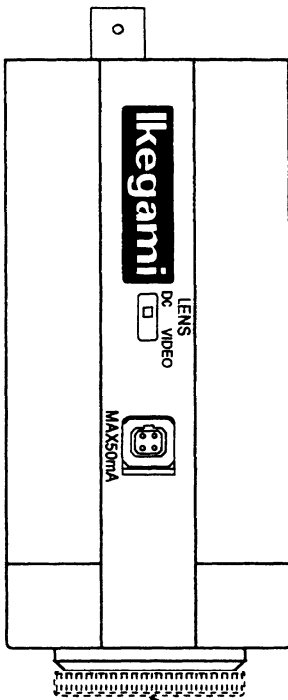
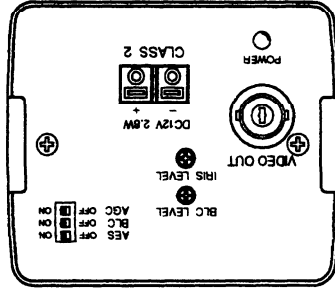

C MOUNT ADAPTOR
(OPTION)

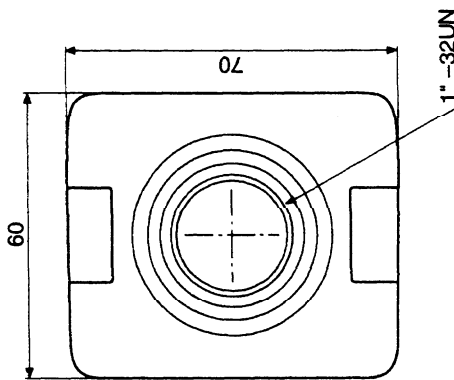

Ikegami

■ **Ikegami Electronics (U.S.A.), Inc.**

37 Brook Avenue, Maywood, New Jersey 07607, U.S.A.
Phone: (201) 368-9171, FAX 201-569-1626

■ **Ikegami Electronics (Europe) GmbH**

Ikegami Strasse 1, 41460 Neuss 1, F.R. Germany
TEL. 02131-123-0/FAX 02131-102820

■ **Ikegami Electronics (Europe) GmbH U.K. Branch**

Kestrel Court, Pound Road, Chertsey, Surrey KT16 8ER, England
TEL. 01-546-7772 & 0932-568966/FAX 0932-569637

Ikegami Tsushinki Co., Ltd.
Printed in Japan.
K16148