

Ikegami

INSTRUCTION MANUAL

MODEL ICD-42A

B/W CCD CAMERA



Thank you very much for your purchase of the Ikegami CCD Camera.
Read this Instruction Manual carefully to keep the camera at full capacity.

Contents

	Page
1. General	3
2. Features	3
3. Composition	3
4. Handling precautions	4
5. Names of parts and their functions	5
6. Connection	8
6-1. Auto iris lens connector	8
6-2. Video output terminal (VIDEO OUT).....	9
6-3. External sync signal input terminal (GENLOCK IN) (option)	9
6-4. Power cord connections	10
7. Lens adjustment.....	12
7-1. Flange focal distance adjustment	12
7-2. Auto iris lens (video iris type) adjustment	14
7-3. Auto iris lens (DC iris type) adjustment.....	15
8. Operation	16
8-1. Power on.....	16
8-2. AGC control	16
8-3. Back-light compensation selector switch (BLC).....	16
8-4. ABC (Automatic Black Control).....	17
8-5. LL PHASE control (on AC type only)	17
9. Warranty and after-sale service	18
10. Specifications	19
11. Appearance view.....	20

OUTDOOR USE WARNING

WARNING — TO PREVENT FIRE OR ELECTRIC SHOCK, DO NOT EXPOSE THIS APPLIANCE TO RAIN OR MOISTURE.

	<p>CAUTION RISK OF ELECTRIC SHOCK DO NOT OPEN</p>		<p>CAUTION: TO REDUCE THE RISK OF ELECTRIC SHOCK, DO NOT REMOVE COVER (OR BACK) NO USER-SERVICEABLE PARTS INSIDE REFER SERVICING TO QUALIFIED SERVICE PERSONNEL.</p>
---	--	---	---



The lightning flash with arrowhead symbol, within an equilateral triangle, is intended to alert the user to the presence of uninsulated "dangerous voltage" within the product's enclosure that may be of sufficient magnitude to constitute a risk of electric shock to persons.



The exclamation point within an equilateral triangle is intended to alert the user to the presence of important operating and maintenance (servicing) instructions in the literature accompanying the appliance.

This device complies with Part 15 of the FCC Rules. Operation is subject to the following two conditions: (1) this device may not cause harmful interference, and (2) this device must accept any interference received, including interference that may cause undesired operation.

CAUTION;
ANY CHANGES OR MODIFICATIONS NOT EXPRESSLY APPROVED BY THE PART RESPONSIBLE FOR COMPLIANCE COULD VOID THE USERS AUTHORITY TO OPERATE THE EQUIPMENT.

IMPORTANT SAFEGUARDS

- **Read Instructions** — All the safety and operating instructions should be read before the appliance is operated.
- **Retain Instructions** — The safety and operating instructions should be retained for future reference.
- **Heed Warnings** — All warnings on the appliance and in the operating instructions should be adhered to.
- **Follow Instructions** — All operating and use instructions should be followed.
- **Cleaning** — Unplug this video product from the wall outlet before cleaning. Do not use liquid cleaners or aerosol cleaners. Use a damp cloth for cleaning.
- **Attachments** — Do not use attachments not recommended by the video product manufacturers as they may cause hazards.
- **Water and Moisture** — Do not use this video product near water — for example, near a bath tub, wash bowl, kitchen sink, or laundry tub, in a wet basement, or near a swimming pool, and the like.
- **Accessories** — Do not place this video product on an unstable cart, stand, tripod, bracket, or table. The video product may fall, causing serious injury to person, and serious damage to the appliance. Use only with a cart, stand, tripod, bracket, or table recommended by the manufacturer, or sold with the video product. Any mounting of the appliance should follow the manufacturer's instructions, and should use a mounting accessory recommended by the manufacturer.

- **Power Sources** — This video product should be operated only from the type of power source indicated on the marking label. If you are not sure of the type of power supply to your home, consult your appliance dealer or local power company. For video products intended to operate from battery power, or other sources, refer to the operating instructions.
- **Grounding or Polarization** — This video product is equipped with a polarized alternating current line-plug (a plug having one blade wider than the other) or a 3-wire grounding-type plug (a plug having a third grounding pin). This is a safety feature. The plug having one blade wider than the other will fit into the power outlet only one way. If you are unable to insert the plug fully into the outlet, try reversing the plug. The plug having a third grounding pin will only fit into a grounding-type power outlet. If the plug should fail to fit, contact your electrician to replace your obsolete outlet. Do not defeat the safety purpose of the polarized plug or the grounding-type plug.
- **Power-Cord Protection** — Power-supply cords should be routed so that they are not likely to be walked on or pinched by items placed upon or against them, paying particular attention to cords at plugs, convenience receptacles, and the point where they exit from the appliance.
- **Lightning** — For added protection for this video product receiver during a lightning storm, or when it is left unattended and unused for long periods of time, unplug it from the wall outlet and disconnect the cable system.
This will prevent damage to the video product due to lightning and power-line surges.
- **Power Lines** — An outside antenna system should not be located in the vicinity of overhead power lines or other electric light or power circuits, or where it can fall into such power lines or circuits. When installing an outside antenna system, extreme care should be taken to keep from touching such power lines or circuits as contact with them might be fatal.
- **Overloading** — Do not overload wall outlets and extension cords as this can result in a risk of fire or electric shock.
- **Object and Liquid Entry** — Never push objects of any kind into this video product through openings as they may touch dangerous voltage points or short-out parts that could result in a fire or electric shock. Never spill liquid of any kind on the video product.
- **Servicing** — Do not attempt to service this video product yourself as opening or removing covers may expose you to dangerous voltage or other hazards. Refer all servicing to qualified service personnel.
- **Damage Requiring Service** — Unplug this video product from the wall outlet and refer servicing to qualified service personnel under the following conditions:
 - a. When the power-supply cord or plug is damaged.
 - b. If liquid has been spilled, or objects have fallen into the video product.
 - c. If the video product has been exposed to rain or water.
 - d. If the video product does not operate normally by following the operating instructions. Adjust only those controls that are covered by the operating instructions as an improper adjustment of other controls may result in damage and will often require extensive work by a qualified technician to restore the video product to its normal operation.
 - e. If the video product has been dropped or the cabinet has been damaged.
 - f. When the video product exhibits a distinct change in performance — this indicates a need for service.
- **Replacement Parts** — When replacement parts are required, be sure the service technician has used replacement parts specified by the manufacturer or have the same characteristics as the original part. Unauthorized substitutions may result in fire, electric shock or other hazards.
- **Safety Check** — Upon completion of any service or repairs to this video product, ask the service technician to perform safety checks to determine that the video product is in proper operating condition.

1. General

The ICD-42A is a CCTV black/white monitor camera that employs a 1/2-inch frame transfer CCD. The high-sensitivity, high-resolution camera can cover a wide spectrum from visible rays to near-infrared rays.

2. Features

- 1) Less-noise, sharper pictures can be achieved even under subject illumination as low as 3 lux (F1.4). The high-sensitivity camera can still provide practical images at the minimum illumination of 0.08 lux (F1.4).
- 2) The camera covers near-infrared rays (about 800 nm) too which is invisible to human eyes.
- 3) The horizontal resolution of 560 lines as well as the horizontal detail compensation function guarantee crisper pictures.
- 4) The built-in automatic black level correction circuit compensates for a reduction in contrast for pictures being shot under near-infrared rays.
- 5) With the backlight compensation circuit incorporated, the auto iris lens enables an effective backlight compensation.
- 6) The camera is equipped with two-way auto iris function for ready use of either the video iris lens or DC iris lens.
- 7) The sync system is available on both the line lock (on AC type only) and the generator lock (GENLOCK) (option). Two or more cameras can be kept in sync within a system.
- 8) With the flange focal distance adjustment mechanism, the focus tracking can be easily adjusted when the zoom lens is used, and focus errors of individual lenses can also be readily corrected.

3. Composition

- | | |
|--|--------|
| 1) CCD camera (ICD-42A): | 1 unit |
| 2) Accessory: Plug connector (E4-191J-100) for auto iris lens: | 1 pc. |
| 3) Instruction Manual: | 1 copy |

4. Handling precautions

- 1) Never disassemble the camera nor expose the internal precision parts. A trouble may result. For adjusting any inner parts, contact a qualified service engineer.
- 2) Do not use the camera in any humid place nor where it may get splashed with water. It is advisable to install the camera in ambient temperatures of -5 to +40°C.
- 3) Keep the supply voltage within the specified ranges.
 - DC type
DC 12V rating: DC 10.5-15V
 - AC 120V type
AC 120V rating: AC 120V \pm 10%
 - AC 24V type
AC 24V rating: AC 24V \pm 10%
- 4) Before installing and cabling the camera, be sure to turn off the power. Be careful not to drop the camera or give it a shock.
- 5) Do not touch the CCD plate with your hand.
- 6) The camera is sensitive to infrared rays. But the lens focus is not the same for visible rays and infrared rays because of the lens aberration. Change the setting according to applications.

5. Names of parts and their functions

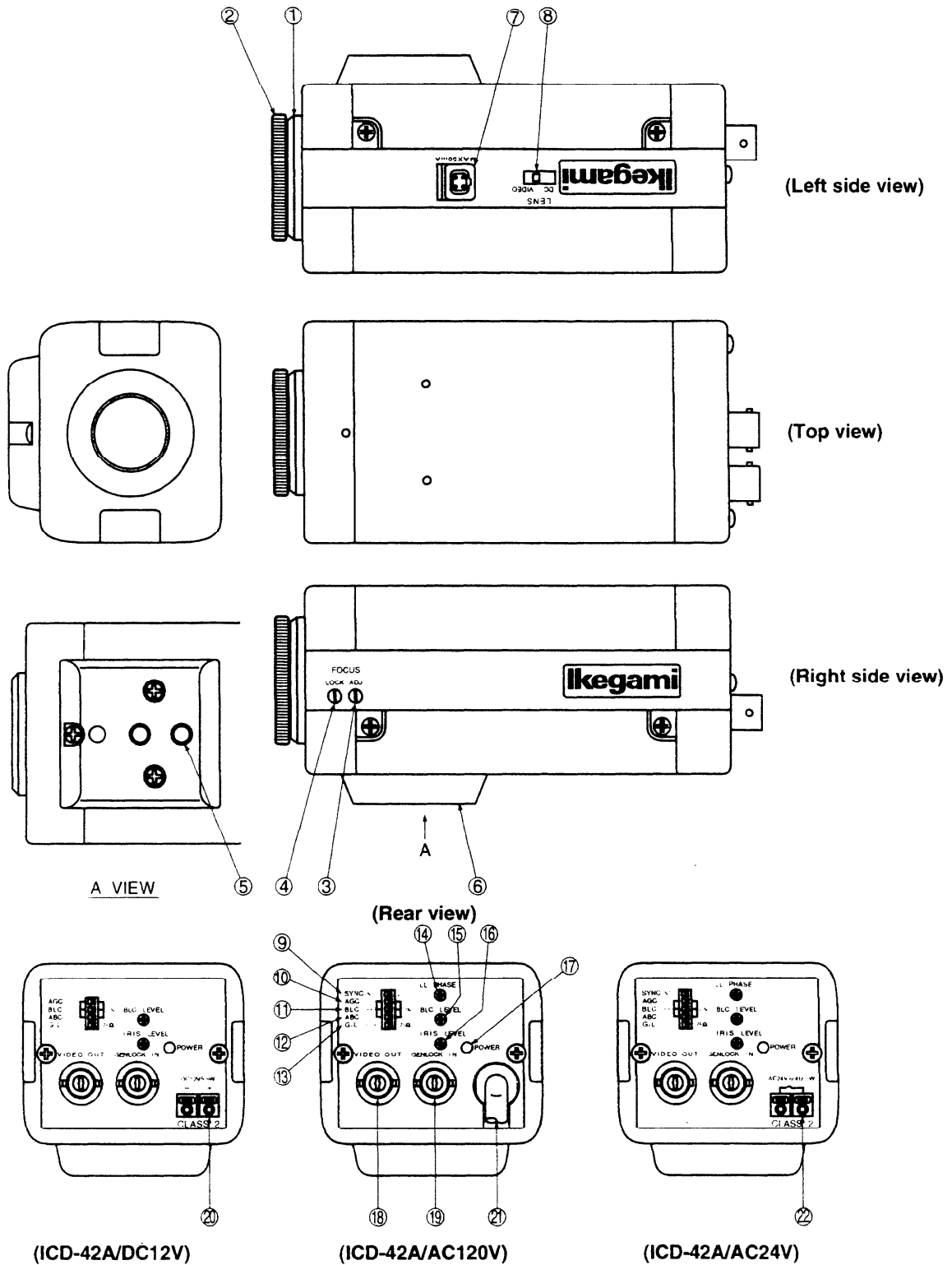

- ① **Lens mount (CS mount)**
Used to install the lens. Accepts many types of CS mount lens.
- ② **C mount adaptor (accessory)**
Attached on the lens amount to accept many types of C mount lenses.
- ③ **Flange focal distance adjuster**
Used to adjust the flange focal distance depending on the lens used. Helpful if the lens' focus ring fails to put into focus.
- ④ **Flange focus lock screw**
Used to mechanically fix the camera's flange focal distance adjuster after its fine adjustment.
- ⑤ **Holder screw hole**
Used to mount the camera onto the camera holder. Also usable for general camera tripods.
- ⑥ **Camera mount**
Can be placed on top of the camera, too, in order to set the camera holder atop. Useful for installing the camera flexibly.
- ⑦ **Auto iris lens connector**
Specifically used to connect the auto iris lens.
- ⑧ **Lens selector switch**
Used to choose between the video iris and the DC iris depending on the auto iris lens in use.
- ⑨ **Internal sync/line lock selector switch**
Used to switch between the internal sync and the line lock. Note that this switch, in any position, works for the line lock alone on the AC type.
- ⑩ **AGC (Automatic Gain Control) switch**
Used to turn on and off the AGC function.
- ⑪ **BLC (Backlight Compensation) switch**
Used to turn on and off the backlight compensation circuit.
- ⑫ **ABC (Automatic Black Control) switch**
Used to turn on and off the automatic black control function.
- ⑬ **External sync 75-ohm termination switch**
Used to change the input impedance for the generator lock. Effective when the optional generator lock is applied. For loop-coupling the generator lock signal using a T-shaped connector, set the switch to the HIGH position. Otherwise, keep it at the 75-ohm position.
- ⑭ **LL PHASE control**
Used to adjust the phase of the line lock.
- ⑮ **BLC LEVEL control**
Used to adjust the backlight compensation level with the BLC switch on.
- ⑯ **IRIS LEVEL control**
Used to adjust the iris level with the DC iris lens in use.

⑰ Power indicator

Stays on in green while the camera power is on.

⑱ Video output terminal

Used to give out the video signal. Connected to the video input terminal of a monitor, switcher, etc. (To be terminated with a 75-ohm impedance)

⑲ External sync signal input terminal (option)

Used to receive the external sync signal.

㉑ DC 12V power input terminal

Used to receive DC 12V power. An input range of DC 10.5-15 V is acceptable.

㉒ AC 120V power cord

Used to allow AC 120V power to pass. An input range of AC 108-132 V is acceptable.

㉓ AC 24V power input terminal

Used to receive AC 24V power. An input range of AC 21.6-26.4 V is acceptable.

6. Connection

6-1. Auto iris lens connector

Use the accompanying auto iris lens control connector

- **For the video type auto iris lens**

Set the lens selector switch to VIDEO position.

— Connector cable leads —

1. Red (power)
2. Not used
3. White (video)
4. Black (shielded)

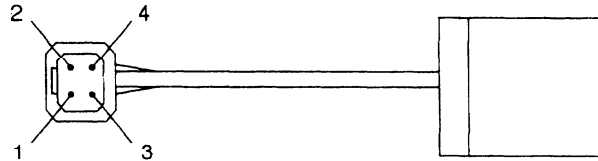

※ Dress the end of the green lead not to allow short-circuit.

- **For the DC type auto iris lens**

Set the lens selector switch to DC position.

— Connector cable leads —

1. Damping coil (-)
2. Damping coil (+)
3. Driving coil (+)
4. Driving coil (-)

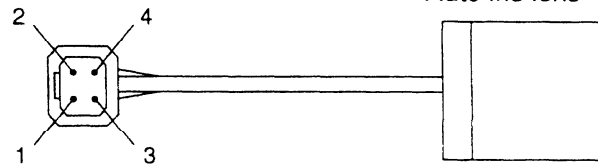

※ Connect the leads as shown above. Refer to the instructions of the lens.

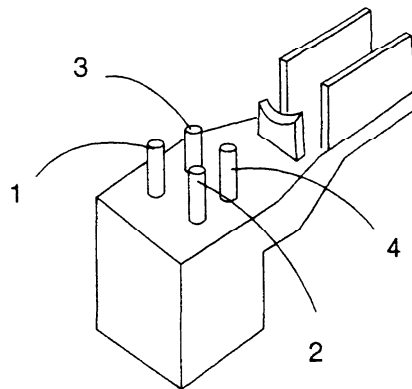

Numbers of connector pins

6-2. Video output terminal (VIDEO OUT)

- This is the output terminal of the video signal.
- The terminal is used to connect the video camera to the video input terminal of a monitor, switcher or the like. (To be terminated with a 75-ohm impedance)
- Use a coaxial cable for connection.

(Typical connections)

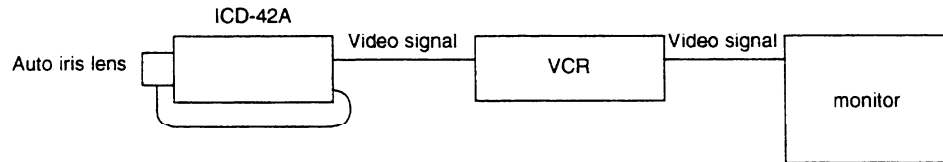

6-3. External sync signal input terminal (GENLOCK IN) (option)

This BNC connector is used to receive the video signal (VS or VBS), black burst signal (BBS) or C.SYNC signal, which is applied as external sync reference.

- Notes:**
- The external sync signals to be received are as follows.

Composite video signal (VS or VBS):	1.0 Vp-p/75 ohms
Black burst signal (BBS):	0.45 Vp-p/75 ohms
C.SYNC signal:	4.0 Vp-p/75 ohms
 - Jitter-prone signals, such as those from VCRs, may cause an out-of-sync state.
 - The generator lock mode needs adjustment of the horizontal phase. Contact a service engineer for this adjustment.
 - For loop-coupling the external sync signal input using a T-shaped connector, set the switch above this terminal to the HIGH position. Otherwise keep the switch at the 75-ohm position.

(Typical connections)

1) One camera

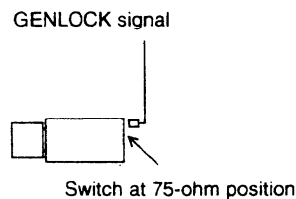

2) Two or more cameras

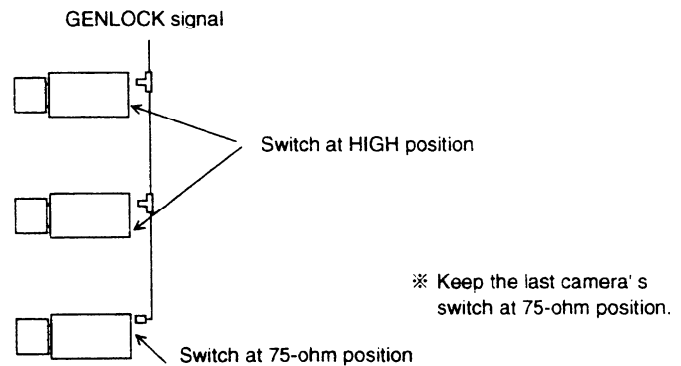

6-4. Power cord connections

- **AC120V type**

Plug the power cord of the camera to an AC120V power outlet.

Caution:

The camera does not have its own power switch. To turn on and off the camera power, plug the power cord in and out of the power outlet.

- **AC 24V type**

AC 24V 60Hz 5W

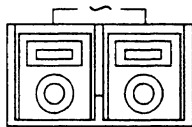

CLASS 2

Supply AC 24V \pm 10%.

※ For connecting the power for AC 24V type unit, be sure to use an insulating transformer for safety.

- **DC 12V type**

DC 12V 5.5W

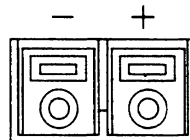

CLASS 2

Supply DC 10.5-15 V.

※ The positive (+) and negative (-) polarities do not matter. When connecting a single power supply to two or more cameras, however, adjust all the cameras for the same polarity.

This installation should be made by a qualified service person and should conform to all local codes.

Caution:

- Make complete connections before supplying the power.
- To turn on and off the power, use the switch of the power unit.
- Connections on power input terminal block
 - (1) Applicable wire thicknesses
 - ① Solid conductor : AWG26-18 (0.4-1.0 mm dia.)
 - ② Flexible stranded conductor : AWG22-20
 - (2) Wire end dressing

Peel off the wire sheath by about 10 mm.
For the flexible stranded wire, twist the conductor well enough.

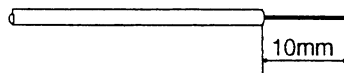

(3) Connections

Note: Be sure to turn off the power switch of the power supply before connecting and disconnecting the wires.

- ① Connecting
 - a. For solid wires with conductor 0.8-1.0 mm in diameter, just insert the wire end into the connection hole of the terminal block.
 - b. For thinner solid wires or flexible stranded wires, hold down the button marked with  on the terminal block using a small bladed screwdriver and insert the wire end into the connection hole.
 - c. Finally, gently pull the wire to make sure the connection is tight.
- ② Disconnecting

Hold down the above  -marked button on the terminal block with the small bladed screwdriver and pull out the wire. If the wire is not easy to pull out, press the button a little harder. Never try to give the wire too strong a pull, because otherwise the wire may be broken.

7. Lens adjustment

7-1. Flange focal distance adjustment

The flange focal distance is the distance between the lens mounting surface and the focal point. In some cases, it is necessary to readjust this distance; that is to say, if the focus ring on the lens fails to give perfect focusing. Use the flange focal distance adjuster shown below.

Before starting the following adjustments, loosen the flange focus lock screw. Finally tighten up this screw again.

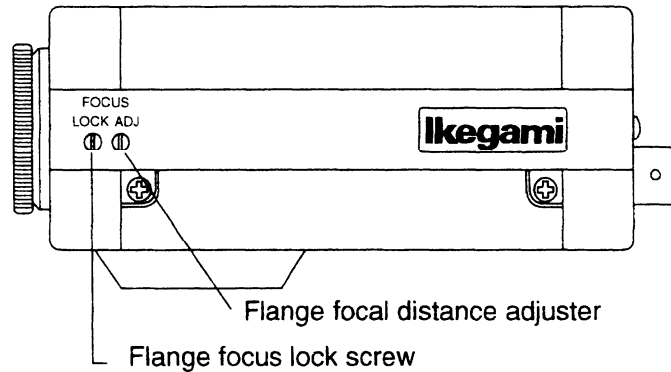

Notes: • Both the C mount lens and the CS mount lens can be used on this camera. Set up the C mount adaptor depending on the lens used. See the table below.

Lens mount	Necessary/Unnecessary
C	Necessary
CS	Unnecessary

- The lens mount dimension "L", shown at right, shall be shorter than 10 mm for the C mount lens and shorter than 5 mm for the CS mount lens. If this dimension is too long, the inside of the camera may get damaged or the lens may fail to attach securely.

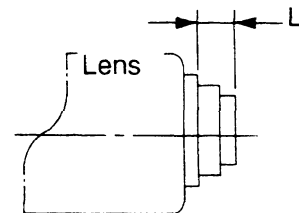

· **When using the fixed focus lens**

- ① Open the iris as much as possible. Set to a distant object and turn the focus ring to bring the object in focus.
- ② Set to an object nearby and turn the focus ring to bring the object in focus.
- ③ If either the distant or the nearby object is not brought into focus, adjust the focus with the flange focal distance adjuster.
- ④ Repeat the above steps several times until the focus can be achieved only with the focus ring for both the distant and nearby objects.
- ⑤ When the auto iris lens is used, position the cord of the lens as shown below. If the lens positioning is specified in the lens instructions, follow it.

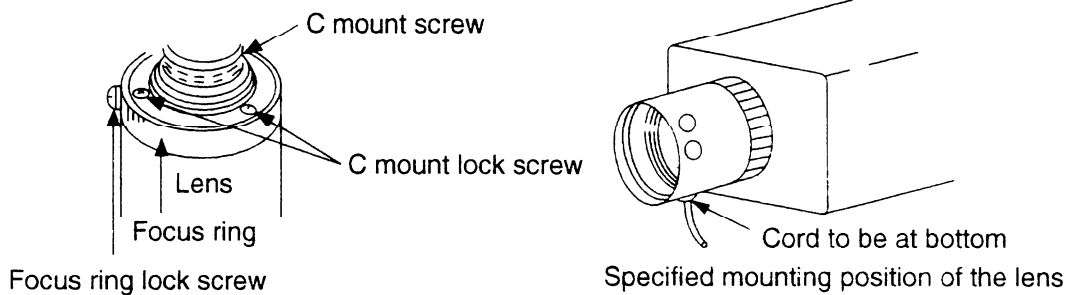

Note:

When adjusting the focus for a distant object, keep the distance more than 2,000 times longer than the focal distance of the lens mounted. (When the lens' focal distance is 7.5 mm, for example, the object should be 15 m or more away.)

· **When using the zoom lens**

- ① Open the iris. Set the zoom lens all the way to the TELE position. Adjust the focus with the focus ring.
- ② Now set the zoom lens all the way to the WIDE position. If the image is out of focus, readjust the focus with the flange focal distance adjuster.
- ③ Repeat the above steps ① and ② several times in order to improve the focus in both the TELE and WIDE positions. Continue this until the best focus is obtained.

Note:

Keep the distance to the object more than 5 times longer than the minimum image forming distance of the lens mounted. (When the minimum image forming distance of the lens is 1 m, for example, the object should be 5 m or more away.)

7-2. Auto iris lens (video iris type) adjustment

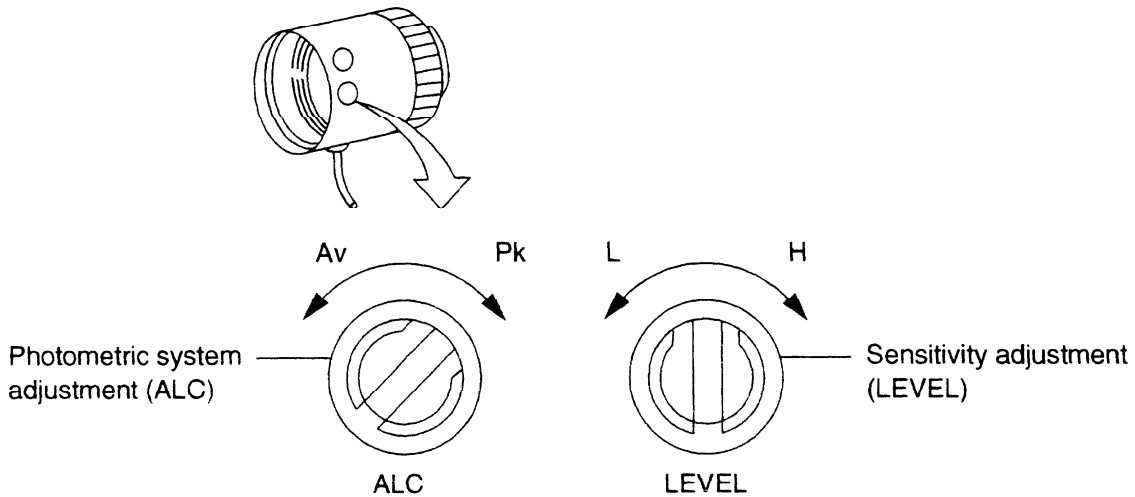

- **Adjust the ALC and LEVEL controls of the auto iris lens in the following conditions.**
 - ① AGC control off
 - ② BLC (backlight compensation) and ABC (automatic black control) switches to be usually set at OFF position
- **Sensitivity adjustment (LEVEL)**

Shoot an object, the contrast of which is relatively low, under sufficient illuminance (over 1000 lux). While watching the monitor screen, adjust the LEVEL control so that the image be appropriate in brightness and tone. For this adjustment, select an evenly lit place and keep the ALC control fully at the Av position.

Turning to H direction : If the entire screen is rather dark, turn the LEVEL control in the H direction to make the screen brighter.

Turning to L direction : If the entire screen is rather whitish, turn the LEVEL control in the L direction to make the screen darker.

· **Photometric system adjustment (ALC)**

While watching the monitor screen, choose a photometric method that suits the object. Adjust the ALC control to obtain an optimum image.

Turning in Av direction : Turn the ALC control in the Av direction for the average photometric method.

At the end of the Av direction, the iris is automatically adjusted with the average video signal level of the object as the right photometric value.

Turning in Pk direction : Turn the ALC control in the Pk direction for the peak photometric method.

At the end of the Pk direction, the iris is automatically adjusted with the high-luminance video signal level of the object as the right photometric value.

Notes:

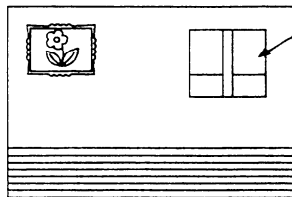

Window

· Let us imagine a scene shown at left. To show the picture hanging on the wall on the screen, turn the ALC control in the Av direction. In this case, the window and the outdoor will be saturated in white.

· Turn the ALC control in the Pk direction to show the window and the outdoor on the screen in the above situation. In this case, the picture and the area around it on the wall will be low in luminance and look dark on the screen.

- If the scene being shot is almost evenly lit, the level will not change much whichever direction the control is turned in.

Notes:

- Make the LEVEL adjustment first and then the ALC adjustment.
- The sensitivity adjustment (LEVEL) is referred to as the video signal level. Do not turn the LEVEL control after the adjustment. Otherwise, the lens' sensitivity may change, resulting in degraded picture quality or malfunction in the worst case.

7-3. Auto iris lens (DC iris type) adjustment

The DC type auto iris lens can be adjusted with the IRIS LEVEL control on the rear panel of the camera.

For the adjustment requirements and procedure, see 7-2. Auto iris lens (video iris type) adjustment.

※ The DC type iris lens does not have the ALC control.

8. Operation

8-1. Power on

The camera of any type does not have its own power switch. Just plug the power cord in and out of a power outlet. To turn on and off the power, use the switch of the power unit.

8-2. AGC control

- 1) Usually keep the control at the ON position.
- 2) Set the control to the OFF position if noises are expected on a dark scene.

8-3. Back-light compensation selector switch (BLC)

When fairly bright light (outside a window, for example) is behind an object, the object looks shadowy. In such a case, the back-light effect should be compensated.

BLC switch at OFF

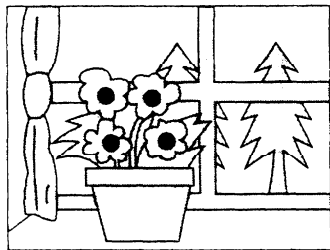

BLC switch at ON

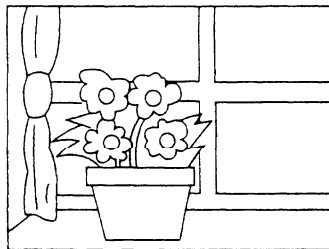

- Typical back-light compensation
Let us look at the sketch at left. When shooting the house plant with the BLC switch off, the flowers will appear very dark because the background is very bright. To make the flowers look better, set the BLC switch to the ON position and adjust the BLC level, while watching the monitor screen, until the flowers appear best. In this case, however, the outdoor landscape appears whitish.
- ※ The BLC function does not make a big difference when the entire scene is dark with no back-light.

Note:

The backlight compensation and automatic black control (discussed on the next page) work in the opposite way to each other. If both the functions are kept on, they may offset against each other, failing to achieve an expected effect. In such case, just use one of the functions you need.

8-4. ABC (Automatic Black Control)

In the range of near-infrared rays, many subjects have high reflectance. The camera is equally sensitive to near-infrared rays. If pure black is always taken as reference, images may become virtually in poor contrast.

In such case, the automatic black control works to pick up the lowest-level portion of the video signal as pure black and to automatically lower the video signal level. When the entire screen is darkish, on the other hand, the black level of the video signal is raised. By so doing, images on the monitor screen can become clearer.

Note:

The automatic black control and backlight compensation (discussed on the previous page) work in the opposite way to each other. If both the functions are kept on, they may offset against each other, failing to achieve an expected effect. In such case, just use one of the functions you need.

8-5. LL PHASE control (on AC type only)

This adjuster is a line-lock phase adjustment control.

In an automatic sequential switching system or the like, which includes two or more cameras, make this phase adjustment to prevent the vertical sync from being disturbed when switching between the cameras. Before making this adjustment, however, firstly pull out the AC plug, reverse its polarities and reinsert the plug. If disturbance still persists, follow the procedure of phase adjustment described below.

- (1) Synchronize the zero-cross points on the AC line with the VIDEO OUT vertical sync phase for adjustment.

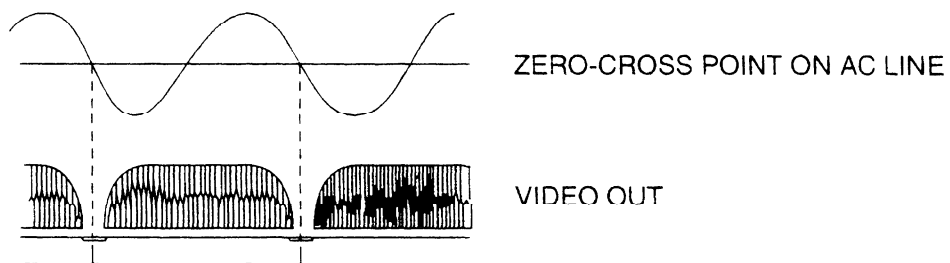

- (2) In a system which two or more cameras are being used, there are sometimes some difference in the AC line phase between the cameras. In that case, take any of the cameras as the basis, and synchronize the phases of the other cameras with that of the reference camera.

9. Warranty and after-sale service

A warranty accompanies this product. Read and fill out the warranty card that you have received at your dealer. Keep this card in a safe place.

- The product is guaranteed for full one year after the date of purchase (consumable parts not covered by the warranty). Your dealer will repair or replace free of charge within the warranty period according to the warranty coverage. For details, refer to the warranty.
 - For repairs after the expiration of the warranty period, consult your dealer or sales representative. It will first be judged whether the trouble is repairable or not. Charged servicing will then be made upon request of the user.
 - Before you ask for servicing, take trouble of reading the Instruction Manual. If the unit still fails, take note of the model number, date of purchase, problem, etc. in detail, and inform your dealer or sales representative.
 - If you have questions about the after-sale service, contact your dealer or sales representative.
- ※ We suggest you ask for preventive inspection earlier.

10. Specifications

1) Imaging device:	1/2" FT-CCD Effective picture elements; 756 (H) x 484 (V)
2) Scanning system:	525 lines at 60 Hz, 2:1 interlace
3) Sync system:	AC type; Line lock (with phase adjuster) (GENLOCK option) DC type; Crystal lock (GENLOCK option)
4) GENLOCK input (option):	VS 1.0 Vp-p, VBS 1.0 Vp-p, C.sync 4.0 Vp-p or BBS 0.45 Vp-p Input allowable level; ± 6 dB Input impedance; 75 ohms
5) Video output:	VS 1.0 Vp-p at 75 ohms
6) Horizontal resolution:	560 lines
7) S/N ratio:	46 dB (p-p/rms) (standard illumination, DETAIL off and WEIGHT on)
8) Subject illumination:	① Standard illumination; About 3 lux/F1.4 ② Minimum illumination; 0.08 lux/F1.4 (Light source; tungsten lamp, colour temperature; 2856K, subject reflectance; 89%, AGC on, without IR cut-off filter)
9) AGC:	ON/OFF switch
10) Gamma:	Fixed at about 0.45
11) White clip:	Fixed at about 0.84 Vp-p
12) Backlight compensation:	ON/OFF switch with level adjustment
13) Auto iris function:	Switchable between video iris and DC iris
14) Lens mount:	CS and C mounts (with C mount adaptor)
15) Flange focal distance adjust mechanism:	Provided
16) Supply power:	① AC 120V $\pm 10\%$, 60 Hz (insulating type) ② AC 24V $\pm 10\%$, 60 Hz (signal insulating type) ③ DC 12V (10.5-15V) (signal insulating type)
17) Power consumption:	① AC 120V type; About 4.5W ② AC 24V type; About 5W ③ DC 12V type; About 5.5W
18) Ambient temperature:	-10 to +50°C
19) Camera mount:	1/4"-20UNC (mountable on top too)
20) Input/output connector:	• VIDEO OUT; BNC • GENLOCK IN (option); BNC • LENS; 4P (applicable plug; E4-191J-100) • AC 24V/DC 12V input; 2P terminal
21) Outer dimensions (WxHxD):	① AC 120V type; 70 x 60 x 160 mm ② AC 24V/DC 12V type; 70 x 60 x 140 mm
22) Weight:	① AC 120V type; About 990 g ② AC 24V/DC 12V type; About 780 g
23) Accessories:	① Instruction Manual; 1 copy ② Auto iris lens connector plug; 1 pc.

11. Appearance view

- ICD-42A/AC120V

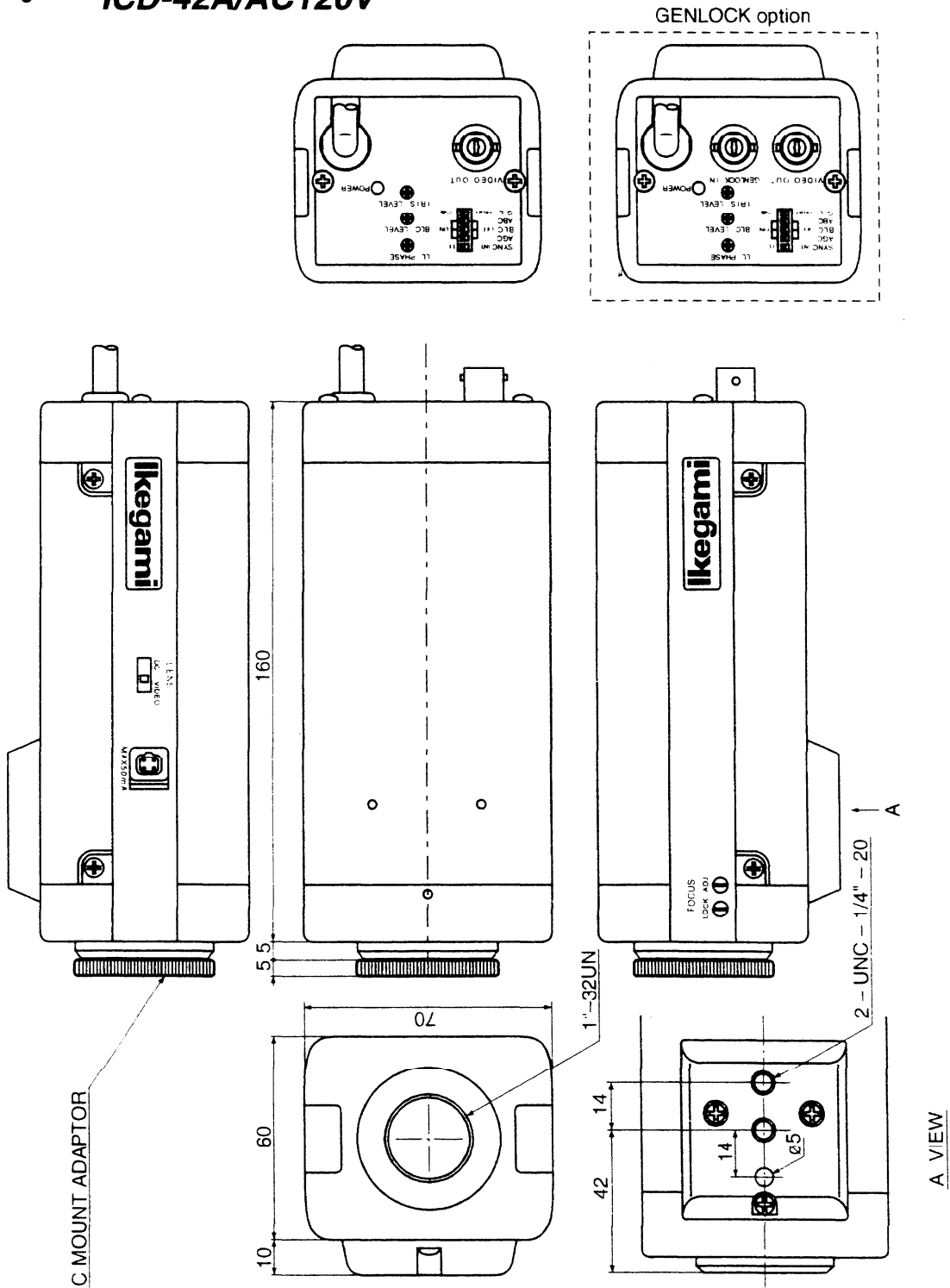

• **ICD-42A/AC24V**

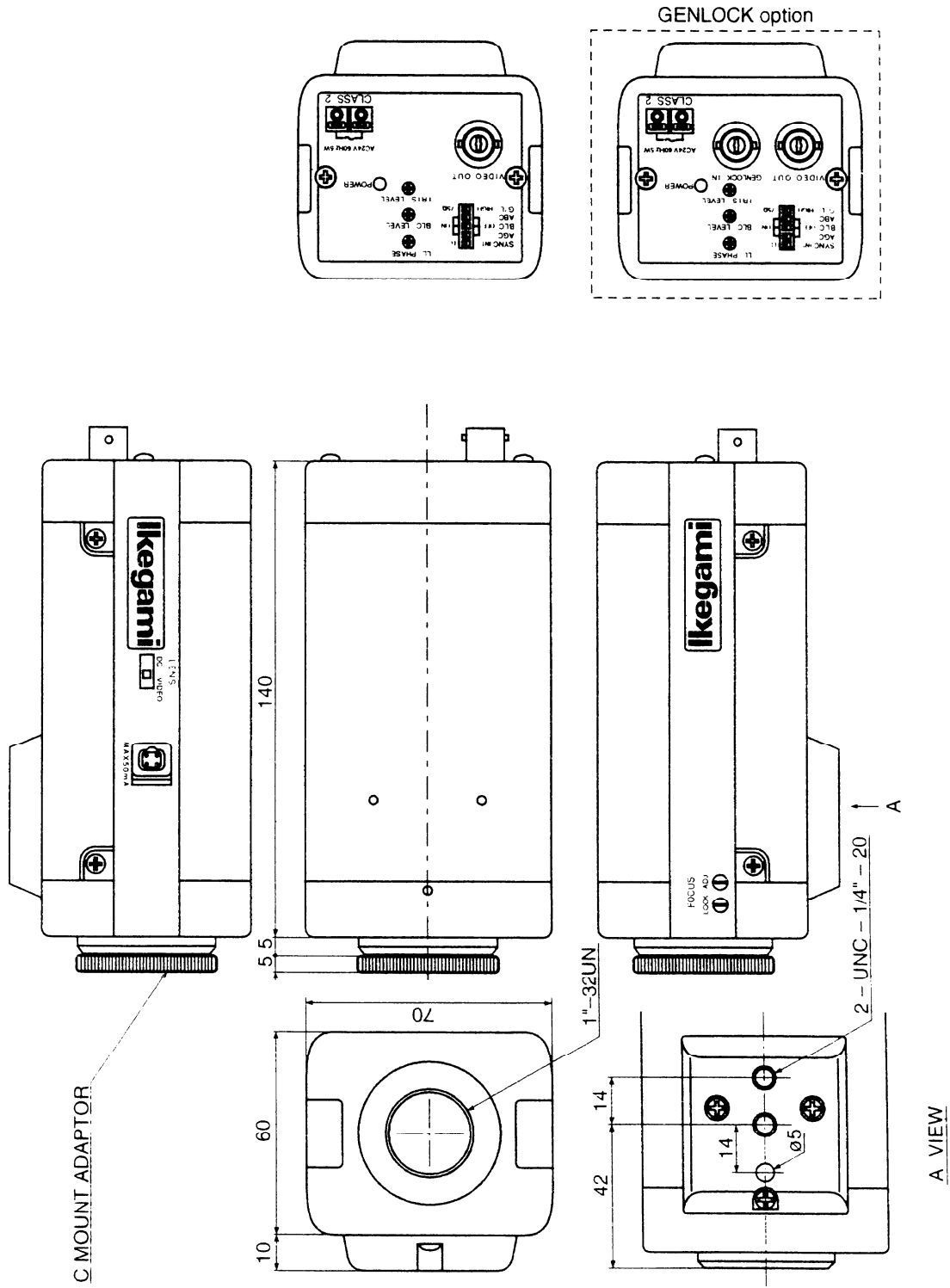

• **ICD-42A/DC12V**

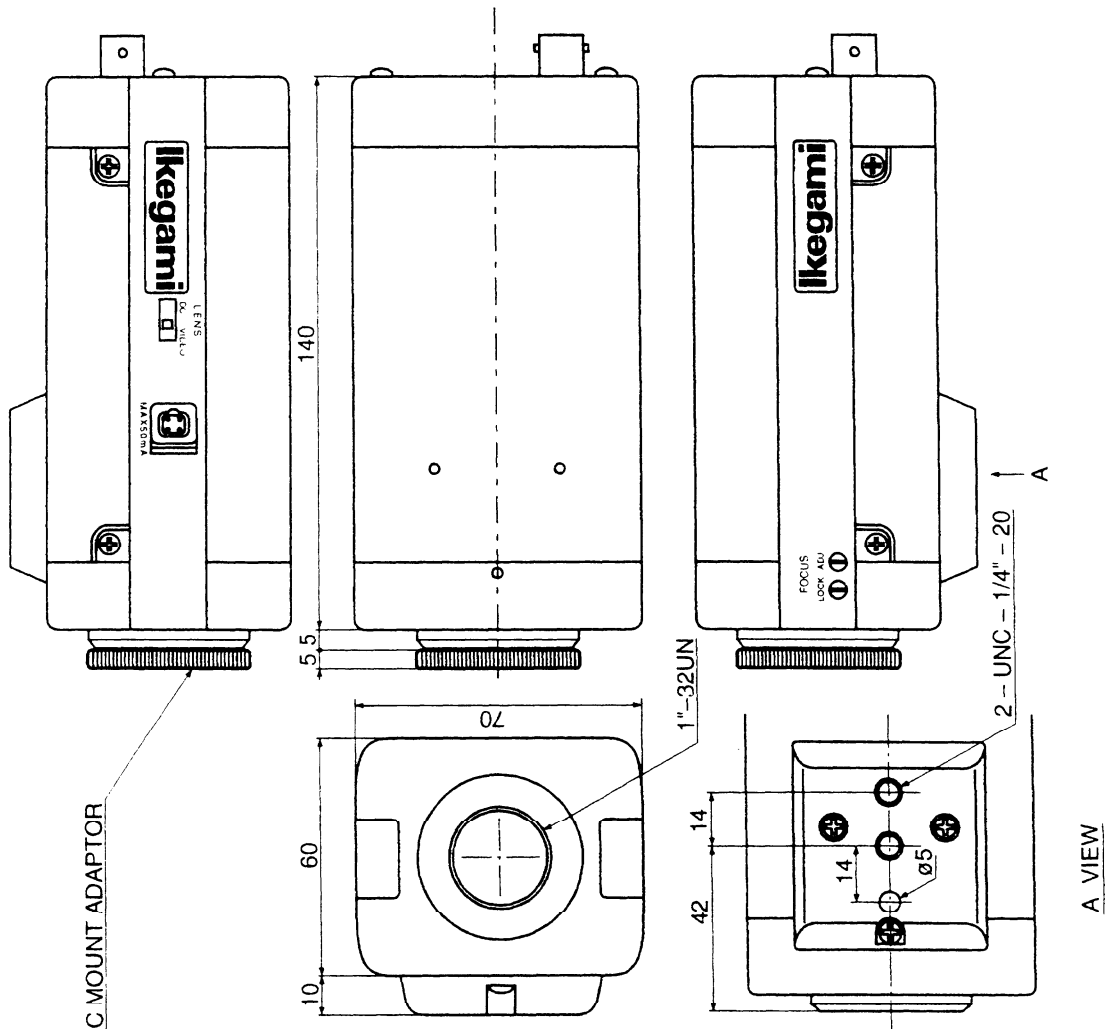
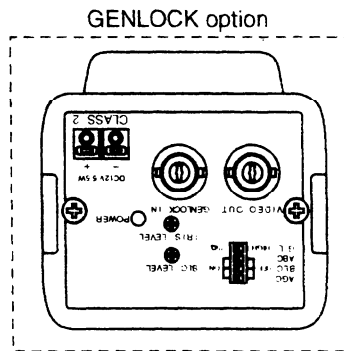
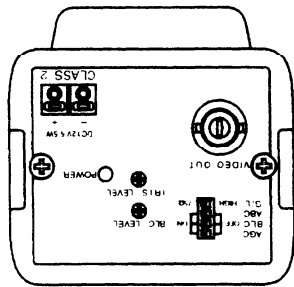

Ikegami

■ **Ikegami Electronics (U.S.A.), Inc.**

37 Brook Avenue, Maywood, New Jersey 07607, U.S.A.
Phone: (201) 368-9171, FAX 201-569-1626

■ **Ikegami Electronics (Europe) GmbH**

Ikegami Strasse 1, 41460 Neuss 1, F.R. Germany
TEL. 02131-123-0/FAX 02131-102820

■ **Ikegami Electronics (Europe) GmbH U.K. Branch**

Kestrel Court, Pound Road, Chertsey, Surrey KT16 8ER, England
TEL. 01-546-7772 & 0932-568966/FAX 0932-569637

Ikegami Tsushinki Co., Ltd.
Printed in Japan.
K07178