

Ikegami

INSTRUCTION MANUAL

MODEL ICD-8024

SINGLE CHIP COLOR CCD CAMERA

OUTDOOR USE WARNING

WARNING – TO PREVENT FIRE OR ELECTRIC SHOCK, DO NOT EXPOSE THIS APPLIANCE TO RAIN OR MOISTURE.

	CAUTION <small>RISK OF ELECTRIC SHOCK READ MANUAL</small>		CAUTION: TO REDUCE THE RISK OF ELECTRIC SHOCK, DO NOT REMOVE COVER (OR BACK) NO USER-SERVICEABLE PARTS INSIDE REFER SERVICING TO QUALIFIED SERVICE PERSONNEL.
---	---	---	---



The lightning flash with arrowhead symbol, within an equilateral triangle, is intended to alert the user to the presence of uninsulated "dangerous voltage" within the product's enclosure that may be of sufficient magnitude to constitute a risk of electric shock to persons.



The exclamation point within an equilateral triangle is intended to alert the user to the presence of important operating and maintenance (servicing) instructions in the literature accompanying the appliance.

Please read this Instruction Manual carefully before use so that you can draw full satisfaction from this model. This model is a single-chip color video camera which is employing CCD (Charge Coupled Device).

You are kindly requested to exempt us from any liability for compensation of the material which was failed to be recorded due to mal-function of the video camera, VTR or recording tape.

CONTENTS

Features	4
Precautions for Installation	4
Name of Each Part and Its Function	5
Lens Selection	6
Mounting of Lens	7
Camera Installation	8
Connecting Procedure	8
Adjustment and Setting (For qualified service personnel only).....	10
Adjustment of Lens	13
Precautions for Use	15
Warranty and After-Sale Service	16
Specifications	17
External View Dimensions	18

This device complies with Part 15 of the FCC Rules. Operation is subject to the following two conditions: (1) this device may not cause harmful interference, and (2) this device must accept any interference received, including interference that may cause undesired operation.

CAUTION;
ANY CHANGES OR MODIFICATIONS NOT EXPRESSLY APPROVED BY THE PART RESPONSIBLE FOR COMPLIANCE COULD VOID THE USERS AUTHORITY TO OPERATE THE EQUIPMENT.

IMPORTANT SAFEGUARDS

- **Read Instructions** — All the safety and operating instructions should be read before the appliance is operated.
- **Retain Instructions** — The safety and operating instructions should be retained for future reference.
- **Heed Warnings** — All warnings on the appliance and in the operating instructions should be adhered to.
- **Follow Instructions** — All operating and use instructions should be followed.
- **Cleaning** — Unplug this video product from the wall outlet before cleaning. Do not use liquid cleaners or aerosol cleaners. Use a damp cloth for cleaning.
- **Attachments** — Do not use attachments not recommended by the video product manufacturer as they may cause hazards.
- **Water and Moisture** — Do not use this video product near water — for example, near a bath tub, wash bowl, kitchen sink, or laundry tub, in a wet basement, or near a swimming pool, and the like.
- **Accessories** — Do not place this video product on an unstable cart, stand, tripod, bracket, or table. The video product may fall, causing serious injury to person, and serious damage to the appliance. Use only with a cart, stand, tripod, bracket, or table recommended by the manufacturer, or sold with the video product. Any mounting of the appliance should follow the manufacturer's instructions, and should use a mounting accessory recommended by the manufacturer.
- **Power Sources** — This video product should be operated only from the type of power source indicated on the marking label. If you are not sure of the type of power supply to your home, consult your appliance dealer or local power company. For video products intended to operate from battery power, or other sources, refer to the operating instructions.
- **Grounding or Polarization** — This video product is equipped with a polarized alternating current line-plug (a plug having one blade wider than the other) or a 3-wire grounding-type plug (a plug having a third grounding pin). This is a safety feature. The plug having one blade wider than the other will fit into the power outlet only one way. If you are unable to insert the plug fully into the outlet, try reversing the plug. The plug having a third grounding pin will only fit into a grounding-type power outlet. If the plug should fail to fit, contact your electrician to replace your obsolete outlet. Do not defeat the safety purpose of the polarized plug or the grounding-type plug.
- **Power-Cord Protection** — Power-supply cords should be routed so that they are not likely to be walked on or pinched by items placed upon or against them, paying particular attention to cords at plugs, convenience receptacles, and the point where they exit from the appliance.
- **Lightning** — For added protection for this video product receiver during a lightning storm, or when it is left unattended and unused for long periods of time, unplug it from the wall outlet and disconnect the cable system. This will prevent damage to the video product due to lightning and power-line surges.
- **Power Lines** — An outside antenna system should not be located in the vicinity of overhead power lines or other electric light or power circuits, or where it can fall into such power lines or circuits. When installing an outside antenna system, extreme care should be taken to keep from touching such power lines or circuits as contact with them might be fatal.
- **Overloading** — Do not overload wall outlets and extension cords as this can result in a risk of fire or electric shock.
- **Object and Liquid Entry** — Never push objects of any kind into this video product through openings as they may touch dangerous voltage points or short-out parts that could result in a fire or electric shock. Never spill liquid of any kind on the video product.
- **Servicing** — Do not attempt to service this video product yourself as opening or removing covers may expose you to dangerous voltage or other hazards. Refer all servicing to qualified service personnel.
- **Damage Requiring Service** — Unplug this video product from the wall outlet and refer servicing to qualified service personnel under the following conditions:
 - a. When the power-supply cord or plug is damaged.
 - b. If liquid has been spilled, or objects have fallen into the video product.

- c. If the video product has been exposed to rain or water.
 - d. If the video product does not operate normally by following the operating instructions. Adjust only those controls that are covered by the operating instructions as an improper adjustment of other controls may result in damage and will often require extensive work by a qualified technician to restore the video product to its normal operation.
 - e. If the video product has been dropped or the cabinet has been damaged.
 - f. When the video product exhibits a distinct change in performance — this indicates a need for service.
- **Replacement Parts** — When replacement parts are required, be sure the service technician has used replacement parts specified by the manufacturer or have the same characteristics as the original part. Unauthorized substitutions may result in fire, electric shock or other hazards.
 - **Safety Check** — Upon completion of any service or repairs to this video product, ask the service technician to perform safety checks to determine that the video product is in proper operating condition.

FEATURES

- **Incorporating Charge Coupled Device (CCD) single chip.**
ICD-8024 incorporates CCD which provides high image burning resistance, geometric distortion and superior resistance to shock and vibration.
- **High resolution, High sensitivity**
Pick-up element is a 1/2" CCD [512(H)x575(V)] pixel 330 TV lines of horizontal resolution and requires a minimum illumination of only 20 Lux at F1.4.
- **Full Auto White Balance through the lens sensor**
TTL (Through The Lens) Full Auto White Balance circuit continuously adjusts the white balance according to the level of the color temperature of the picture.
- **1/1000 sec. high speed shutter**
The effect shutter uses a speed of 1/1000 sec. which enables precise, blur-free recording of high speed action, provides clear picture in stop-motion and also excellent slow motion reproduction.
- **C-mount**
Various types of C-mount lenses can be mounted.
- **Easy installation**
Camera mount can be positioned at either upside or downside according to the installation conditions. Compact and light weight design enables the installation in anywhere desired.
- **AC power operation**
ICD-8024 can be operated by AC24V power source. Without the need for DC power, the installation is made easily.
- **Line lock**
Line lock can be made where the power frequency is 60Hz. No folding of pictures will occur even when switching is made among more than two cameras.

PRECAUTIONS FOR INSTALLATION

- **Never expose the unit to rain or water.**
Water intrusion can be a cause of trouble or accident.
- **Use within the range of specified operating temperature.**
When used in extremely hot or cold place where the temperature goes beyond the specified operating temperature range (-5°C — $+45^{\circ}\text{C}$), the adverse effect will be exerted on the picture or the parts and lead to trouble.
- **Avoid installation in extremely humid or dusty place.**
Adverse effect will be exerted on component parts.
- **Avoid installation in the place where radiant ray or X-ray exists.**
Adverse effect will be exerted on CCD or other component parts and lead to trouble.
- **Avoid installation in the place where powerful radio wave or magnetism exists.**
Adverse effect will be exerted on the picture.
- **Avoid installation in the place subject to extreme vibrations.**
Adverse effect will be exerted on the picture or the component parts.

Prior to use, please read carefully Precautions for Use on page 15.

NAMES OF EACH PARTS AND ITS FUNCTIONS

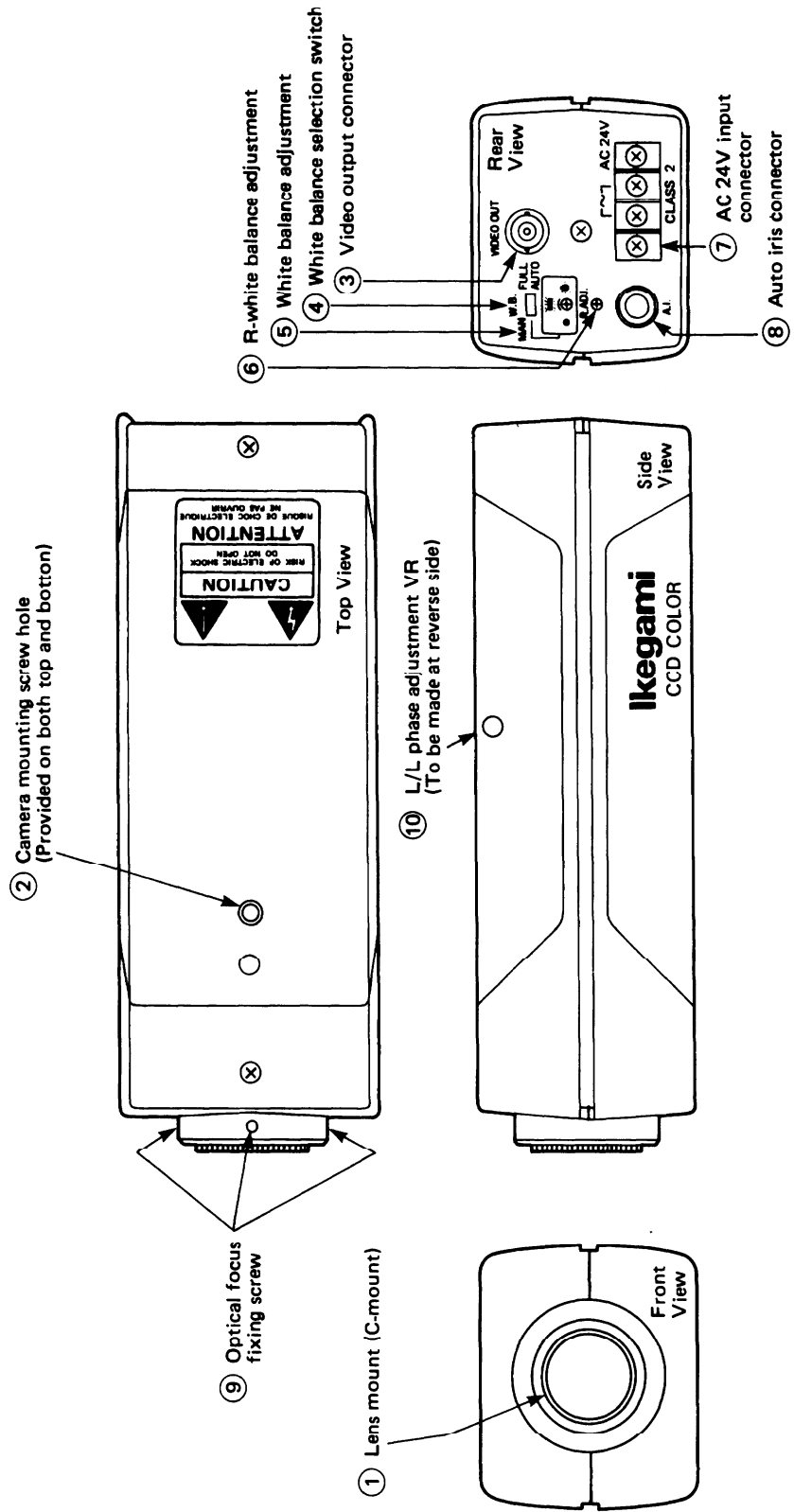

① **Lens mount (C-mount)**

Various types of C-mount lenses are available. (See below.)

② **Camera mounting screw hole**

The camera mounting screw hole (UNC-1/4"20) is provided on each of top and bottom face. This hole is used to mount the camera on a mounting holder, bracket or tripods etc. (See page 8.)

③ **Video output connector (VIDEO OUT)**

Output connector (BNC connector) of the video signal which is connected to the video input connector of monitor or switcher. (75Ω termination)

④ **White balance selection switch**

This switch is used to select TTL or manual position. (See page 11).

⑤ **White balance adjustment**

Adjust the white balance by this volume when the white balance selection switch is set to the manual position. (See page 11.)

⑥ **R-white balance adjustment (R.ADJ)**

Adjust the white balance by this volume when the white balance selection switch is set to the manual position. (See page 11.)

⑦ **AC 24V input connectors**

The connectors receive AC24V (60Hz) input. (See page 9.)

⑧ **Auto iris connector (A.I.)**

Iris cord of Auto iris lens is connected to here. Use the lens equipped with specially designed plug. (R05-PB3M manufactured by Tajimi.) (See page 8.)

⑨ **Optical focus fixing screw**

When the image cannot be focused by the focus ring of the lens, loosen this screw and adjust the flange-back (distance from the lens fitting face up to the image forming face). After adjustment, tighten the screw again. (See page 13.)

⑩ **L/L phase adjustment VR**

While line lock is made, the V.SYNC phase of output against AC power line can be changed by this control, so that the phase can be matched with other cameras. (See page 13.)

LENS SELECTION

- Use the C-mount lens for 1/2" video camera.
- Select the lens which can provide desired view range (picture range).
If object size and the distance between the object and the lens are known, a lens of the proper focal length must be selected. The proper focal length can be determined by the following equations. (The equation offers a guideline when the

distance (L) between the lens and the object is more than 100 times of the lens focal length. The value thus obtained should be regarded as reference value only.)

Equation to obtain picture range	$H = \frac{4.8 \times L}{f}$	$W = \frac{6.4 \times L}{f}$
----------------------------------	------------------------------	------------------------------

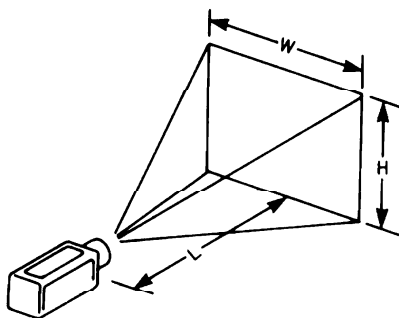

- H: Height of object (m)
- W: Width of object (m)
- L: Distance between lens and object (m)
- f: Focal length of lens (mm)

Cautions

- Use the auto iris lens which is powered by DC 9 V and consumes less than 50 mA.
- The mounting dimensions of the lens, shown in the diagram, otherwise the lens will damage the camera.
- A B/W lens is available, however please note that some lenses can deteriorate color reproduction level and picture quality. (Please pay attention especially when is used outdoor or in extremely bright place.)

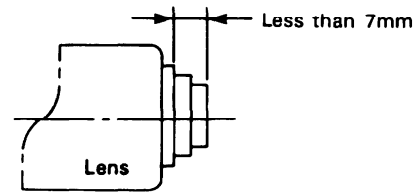

MOUNTING OF LENS

- 1 Remove the lens mount cap.
- 2 Mount the Auto Iris Lens by turning it clockwise into the lens mount of the Camera. Screw it in until it is completely fixed.
- 3 When using the auto iris lens, connect the auto iris cable connector (3-pin type) to the auto iris connector on the rear panel of the camera. (See below.)

* Use the auto iris lens which controls video signal as input signal.

Cautions

- Read carefully the instructions of the lens, too.
- Auto iris lens is recommended to draw full benefits of the camera functions.
- After lens mounting, the flange-back adjustment is sometimes required. And when using the auto iris lens which controls video signal as input signal, the additional adjustments of lens level and ALC volume is sometime also required. (See pages 13 and 14.)

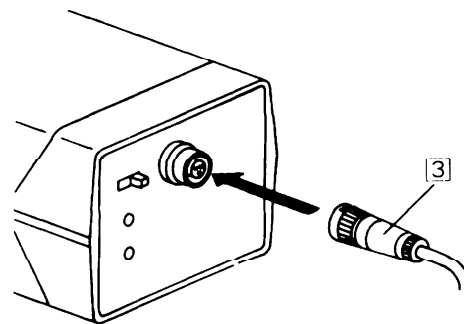
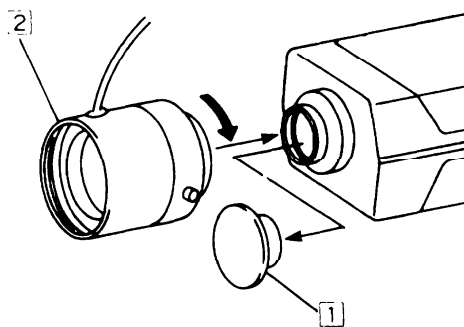

CAMERA INSTALLATION

- With the camera mounting screw hole (UNC 1/4"×20) provided on each of top and bottom faces, the camera unit can be mounted on tripods or camera holder on either side.

Caution

- The length of the fitting screw used on tripods or camera holder should be less than 5.5 mm.

< Installation on tripods >

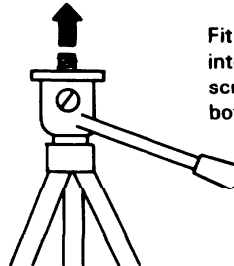
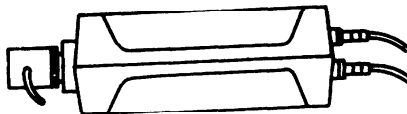

Fit the screw on the tripods into the camera mounting screw hole on the camera bottom face, and tighten it.

< Installation on camera holder >

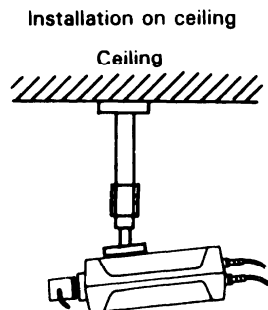
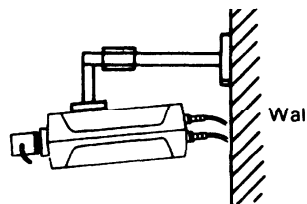
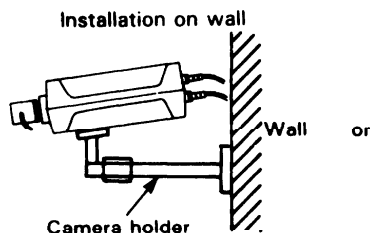

Installation on shelf

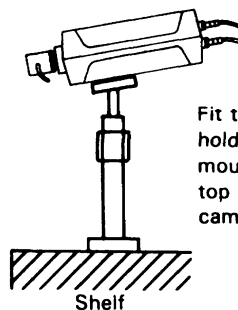

Fit the screw on the camera holder into the camera mounting screw hole on either top or bottom side of the camera, and tighten it.

CONNECTING PROCEDURE

- Keep the camera and connected equipment power switched OFF during installation.
- Read carefully the instructions of each equipment to be connected.

Cautions

- Use the auto iris lens which is powered by DC 9V and 50mA. Max.

1 Auto iris connector (A.I.)

- Connect the iris cord of the auto iris lens.
- When the iris cord connector plug is different, use the attachment special iris connector plug (3-Tojimi R05 PB3M).

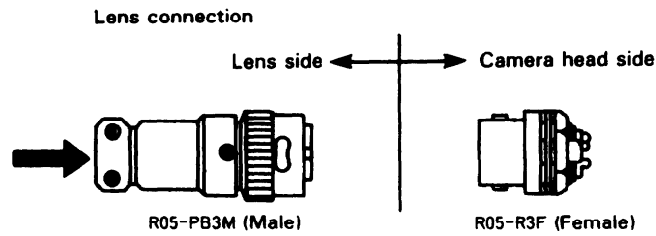

Viewed from arrow side

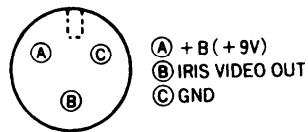

Auto iris lens

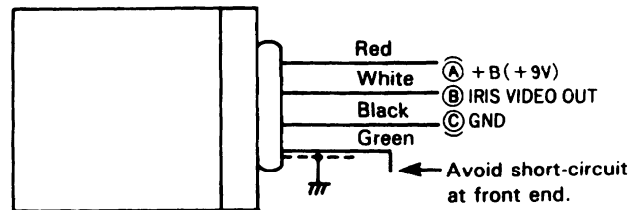

2 Video output connector (VIDEO OUT)

- Output connector (BNC connector) of the video signal.
- Video output signal is fed to a video monitor or VTR by the coaxial cable with a BNC connector.

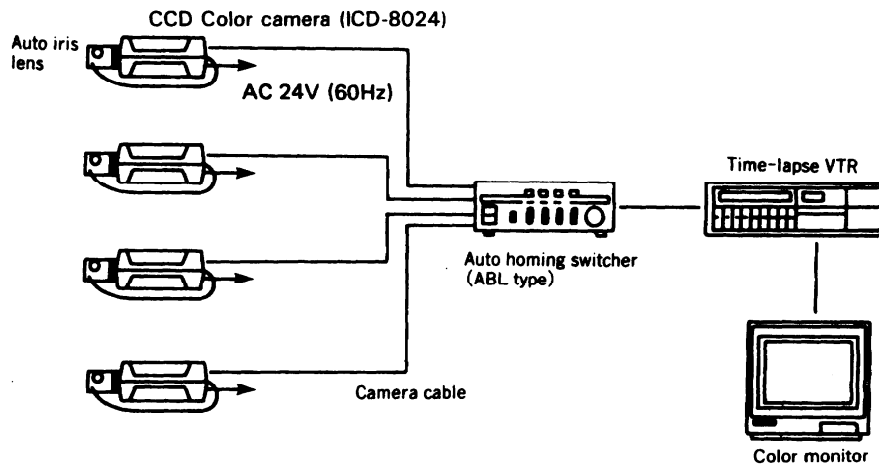

3 Power input

- In case of ICD-8024

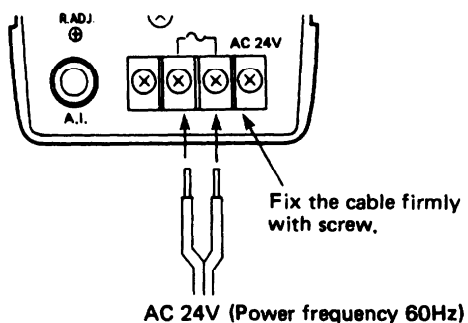

Cautions

- Be sure to make power connection as the final step.
- Before connecting the power, turn off the power of each connected equipment.

ADJUSTMENT AND SETTING

- When adjustments for each functions are required, The top and bottom cases can be removed by removing the screws (4 pieces on the top, 2 pieces on the bottom) in the following drawing.

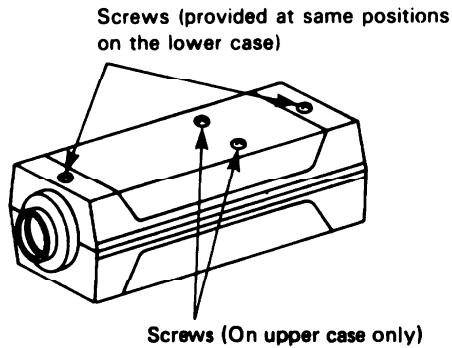

■ AGC (Automatic Gain Control) selection

- Sensitivity level is automatically raised by this function when luminance of the object is insufficient.
- AGC position: AGC function works.
MANU. position: AGC function does not work.

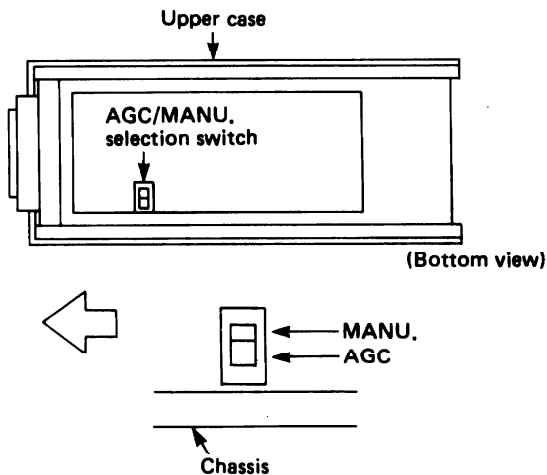

Cautions

- When setting the AGC switch, remove lower case only.
- When AGC function is working, the picture is roughened to some degree.
- The switch is factory preset to the AGC position at factory.

■ Shutter speed selection

- Shutter speed (accumulation time for signal charge) can be changed by this function. When the high speed motion is reproduced in stop-motion or in slow mode, the picture normally goes out of clear focus. By switching the shutter speed from 1/60 second (normal) to 1/1000 second, even the high speed motion can be pictured clearly.

NORM position: Shutter speed is 1/60 second (normal)

SHUT position: Shutter speed is 1/1000 second

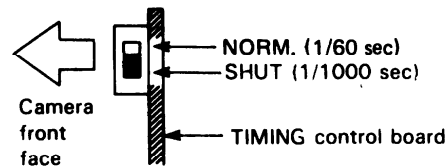
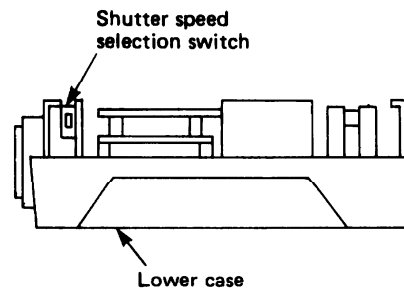

Cautions

- When setting the shutter speed, remove the upper case only.
- When the shutter speed is set to 1/1000 second (SHUT position), higher brightness is required than the NORM. position. Use this shutter speed in bright place such as outdoor on fine day. (The sensitivity when this switch is set to the SHUT position is approx. 1/17 of the sensitivity when the switch is set to the NORM position.)
- When the shutter speed is set to 1/1000 second (SHUT position), the flickers are emphasized under the illumination lighting (fluorescent lamp in particular). The smearing (vertical or horizontal trailing image), which is inherent to the CCD camera, is further emphasized.
- When the shutter speed is set to 1/1000 second (SHUT position), avoid fluorescent lamp lighting if possible, which can cause periodic color irregularity.
- This switch is factory preset to the NORM position at factory.

■ White balance adjustment

- The color temperature is compensated by this function. Adjustment is made to reproduce the most natural color depending on the color temperature of the lighting source for the object. (To make color confirmation, please see the color monitor which is correctly adjusted.)

• White balance adjustment selection switch

FULL AUTO position:

The white balance is set by the automatic follow-up system (color temperature range of approx. 2500°K – 9000°K), which adjusts the balance automatically according to the color temperature of the light source. (The automatic color temperature follow-up system used in this model is the TTL (Through The Lens) system, which sensors the color temperature of the light source coming through the lens and, according to it, automatically adjusts the balance.)

MAN. position:

The white balance can be adjusted manually.

• Manual white balance adjustment

- ① Set the white balance selection switch on the rear panel to MAN. position.
- ② Monitor the all white object such as white wall paper on the full screen.
- ③ Adjust the color temperature change with the control on the rear panel. The range of adjustments by the control is as follows.

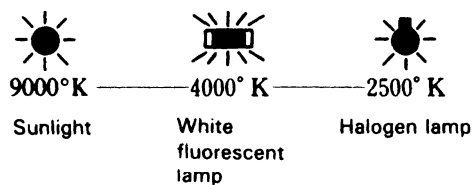
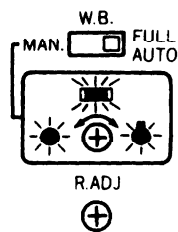

- ④ The white balance adjustment can produce red (or green) shade in the picture. Adjust with R.ADJ. control so that the screen color may become natural.

* If the white balance is to be adjusted with special accuracy, use the vector scope.

Cautions

- The automatic color temperature follow-up function may not work well when the light source is special and out of the adjustment range. When the colored object, particularly of single color, is pictured (or appears largely on the screen), the color temperature difference may be produced between the object and its surroundings due to the use of the TTL system, causing the imperfect white balance. In such case, adjust the white balance manually by setting the switch to the MAN. position.
- Though it rarely happens, the automatic color temperature follow-up function may saturate in such case when the color temperature has been changed drastically. In the case, power off the unit and, after 10-20 seconds, power it on again. The function is reset, and the correct white balance is obtained.
- When panning or tilting motion is performed by the rotary table, it is recommended to set the switch to the MAN. position. When the switch is set at the FULL AUTO position, the white balance varies according to object and may produce unclear picture in some cases.
- The switch is factory preset to the FULL AUTO position at factory.
- Refer to the summary on page 12 as the guide for color temperature and brightness.

• Guide for brightness expression in figures

10		• Candle light (20 cm away) (10-15)
100	<ul style="list-style-type: none"> • Indoor golf practice yard (200-300) • Fluorescent lamp 30W x 2 (300) • Desk under fluorescent lighting (400) • Office room under fluorescent lighting (400-500) • Bowling play hall (500) • Department store (500-700) 	<ul style="list-style-type: none"> • Flashlight (1 m away) (250) • Subway platform (300) • Boutique (400-500) • Public library (400-500)
1,000	<ul style="list-style-type: none"> • Sunlight 1 hr before sunset on fine day (1,000) • Sunlight 1 hr after sunrise on cloudy day (2,000) 	<ul style="list-style-type: none"> • Subway coach (500) • Station ticket gate (650) • Well-lighted room (1,000)
10,000	<ul style="list-style-type: none"> • Sunlight at 10 AM on cloudy day (250×10^2) • Sunlight at noon on cloudy day (320×10^2) • Sunlight at 3 PM on fine day (350×10^2) • Sunlight at 10 AM on fine day (650×10^2) 	<ul style="list-style-type: none"> • Window side of office room under fluorescent lighting (1,000)
100,000 lux	<ul style="list-style-type: none"> • Sunlight at noon on fine day ($1,000 \times 10^2$) 	

* Shown above are the approx. values and for reference only. Use this table as a guide to estimate brightness level.

• Color temperature of light source

The color temperature is a measure used to indicate the nature of the light and expressed in the unit of Kelvin (K).

The higher the value, the more the blue shade. The lower the value, the more the red shade. (Color temperature has no direct relation with brightness.)

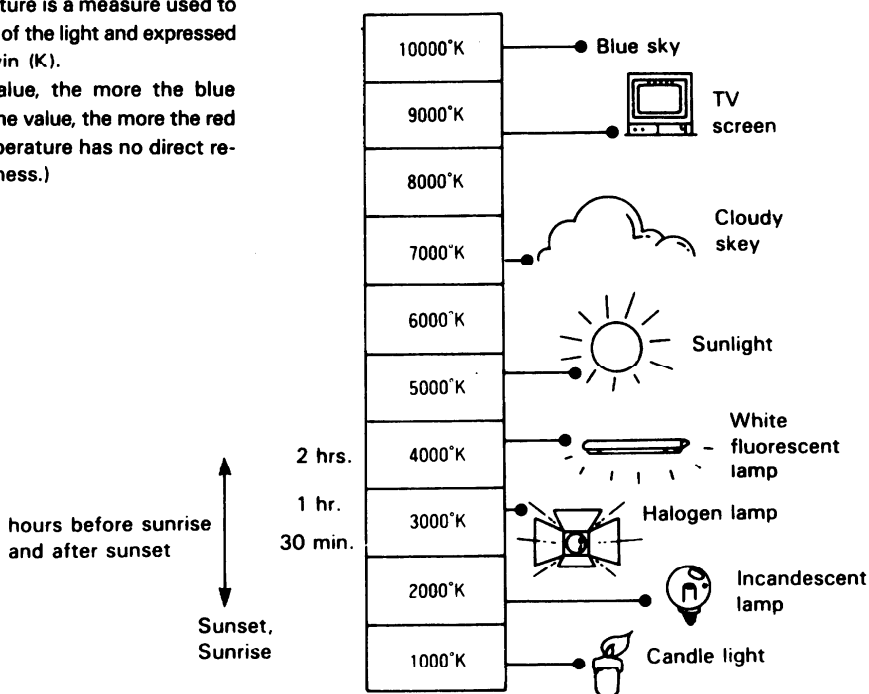

■ Line Lock Adjustment

- Switching of internal sync and line lock Internal sync mode or line lock mode can be selected by the switch provided on the line lock board.

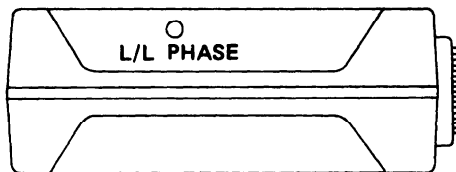
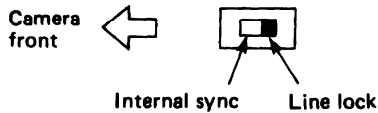
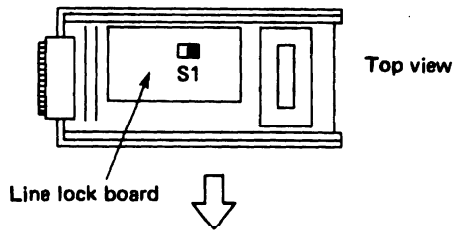

The V.SYNC phase of camera output can be changed $\pm 90^\circ$ from the zero-cross point of AC line power input. Make adjustment so that the phase of each camera becomes identical.

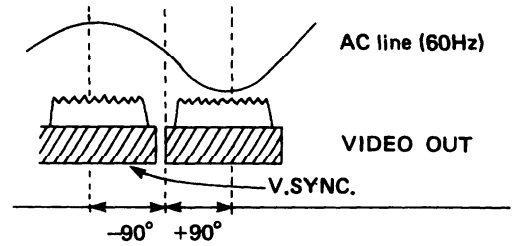

Caution Line lock will not work unless power frequency is 60Hz.

ADJUSTMENT OF LENS

■ Adjustment of flange-back

After lens mounting, the adjustment of flange-back (distance between the lens mounting face and the image forming face) is required in some cases. When the image is not focused clearly by the focus ring of the lens, make adjustment by the optical focus fitting screw as shown below.

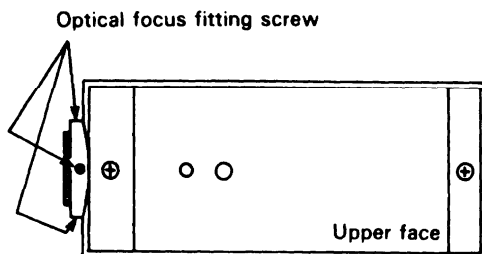

• When using fixed focus lens

- ① Open the iris as much as possible, and set to the distant object. Turn the focus ring to fix the focus.

- ② Set to the object nearby (approx. 30 cm), and fix the focus by the focus ring.
- ③ When the focus is not fixed for the distant or the nearby objects, loosen the optical focus fitting screw and turn the C-mount of the camera together with the lens until the focus is clearly fixed.
- ④ Repeat the above procedures several times until the focus can be fixed only by the focus ring for both distant and nearby objects. After this, tighten the optical focus fitting screw.
- ⑤ When the auto iris lens is used, loosen the C-mount fitting screw and turn the C-mount so that the lens can be mounted properly on the specified position of the camera. After this, tighten the C-mount fitting screw. (See the figure below.)

* The construction may differ on different lenses. Please refer to the instruction of the lens.

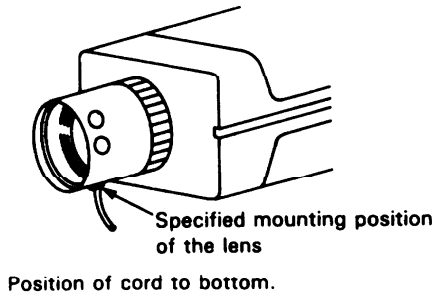
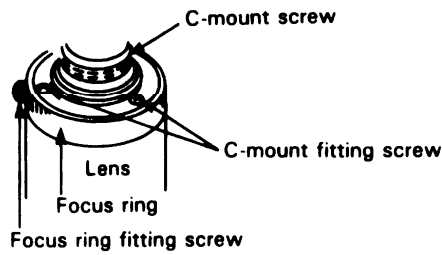

Cautions

- When fixing the focus for distant object, keep the distance more than 2,000 times of the focal length of the mounted lens. (When the lens focal length is 7.5 mm, for example, the distance should be more than 15 m.)

• When using zoom lens

- ① Set the iris to open, and zoom the lens to the maximum TELE position. Fix the focus by the focus ring.
- ② When the image is out of focus with the lens zoomed to the maximum WIDE position, loosen the optical focus fitting screw and turn the C-mount of the camera together with the lens until the focus is fixed.
- ③ Repeat the above procedures ① and ② several times and reduce the deviation of focus in both TELE and WIDE positions.
- ④ After the best focus is obtained, tighten the optical focus fitting screw.

Cautions

- Keep the distance to the object more than 5 times of the minimum image forming distance of the mounted lens. (When the minimum image forming distance of the lens is 1 m. for example, keep the distance more than 5 m.)

■ Adjustment of auto iris lens

When using the auto iris lens which controls the video signal as input signal, make adjustment if necessary.

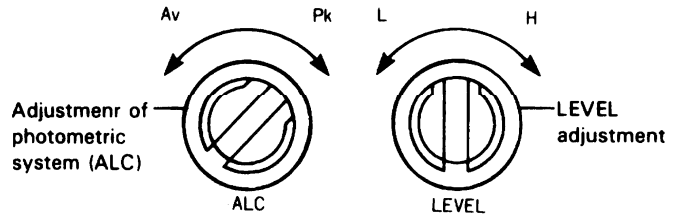
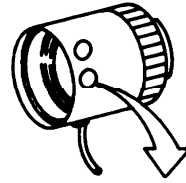

• LEVEL adjustment

To make level adjustment, picture the proper object having comparatively low contrast with sufficient luminance (more than 1000 lux). While monitoring on the screen, adjust the image until it has optimum brightness and color gradation. Select the place with uniform brightness, and set the ALC adjuster to the maximum AV side.

Turn to H: When the whole screen is dark or showing noise, turn the control to H side until optimum brightness is obtained.

Turn to L: When the whole screen looks whitish and the colored section carries white color, turn the control to L side until optimum brightness is obtained.

• Adjust of photometric system (ALC)

While monitoring the screen, select the photometric system suitable for the object to obtain the optimum image.

AV side: Average photometric system is selected by turning the control to AV side. When the control is set to the AV end, the iris is automatically adjusted by using the average of the video signal level from the object as the optimum photometric value.

PK side: Peak photometric system is selected by turning the control to PK side. When the control is set to the PK end, the iris is automatically adjusted by using the peak luminance value of the video signal from the object as the optimum photometric value.

Cautions

- When such painting on the wall as shown in the figure is to be pictured, turn the control to AV side for adjustment.

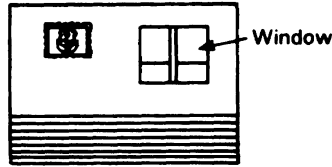

In this case, the pictures for the vicinity of the window and for outside of the window are saturated to be seen as white.

- When the vicinity or the outside of the window is to be pictured, turn the control to PK side. In this case, the vicinity of the painting looks dark on the screen due to dropping of the level.
- When the whole place pictured has almost the same brightness, the level is scarcely changed by turning of the control to either AV side or PK side.

Cautions

- Adjust ALC only after the LEVEL adjustment.
- The LEVEL adjustment is the adjustment of the video signal level. Never turn the control randomly once it has been adjusted. Otherwise, the lens sensitivity will change to deteriorate the picture quality or may lead to the operational failure.

PRECAUTIONS FOR USE

- **Never direct the camera to the sun.**
Avoid directing the lens to the sun regardless of whether the camera is used or not.
- **Never picture too intensive light.**
An object of high luminance (intensive light) in a part of the screen can cause trailing image either vertically or horizontally. This is known as smearing which is inherent to the charge coupled device, and should not be regarded as failure.
- **Never disassemble the unit.**
Keep off hands from the internal components. Otherwise failure or accident may result.
- **Avoid foreign matters from entering the unit.**
Never allow metallic or flammable object to enter. Otherwise failure or accident may result.
- **Handle the unit carefully.**
Never drop the unit, or give strong impact or vibration. Otherwise failure or accident may result.

■ On detection of abnormality or failure

When abnormal condition (abnormal noise, smell, smoke, etc.) or failure (sudden disappearance of picture, etc.) occurs, power off the unit immediately and contact Ikegami dealer.

Maintenance

- Turn the power off, and wipe the unit with soft dry cloth. When the dirt is hard to be removed, wet the cloth with furniture detergent thinned with water. Squeeze the cloth well and wipe the unit lightly. To clean the lens, use the camera blower or lens cleaning paper.

WARRANTY AND AFTER-SALE SERVICE

The unit accompanies the certificate of warranty. Please receive the certificate at the time of your purchase, and fill up the required places on it. Read the contents and keep it with care not to miss.

- The period of warranty is one year from the date of purchase. (Consumables are excluded.) Repairs will be done by the dealer who sold the unit according to the conditions stipulated on the certificate. Please read the certificate for more details.
- For the repairs after termination of the warranty period, consult Ikegami dealer or salesman. When the unit's function can be recovered by repair, the repair service will be available at cost according to user's request.
- Before calling for repair, please read the instruction manual again for double-check. Then, inform the dealer of model number, date of purchase, state of trouble, etc. in as much detail as possible.

- If there is anything unclear about after-sale service, consult the dealer or salesman.
 - * It is recommended that periodical maintenance inspection be made on earlier occasion whenever possible.

Related Products

- ICD-8012
 - * This is the camera which can be operated with DC12V power.
- AC-800
 - * This is the AC adaptor which enables the operation of ICD-8012 with AC117V.

SPECIFICATIONS

Camera system	1/2" Interline transfer CCD	
Colour filter	Ye, Cy, Mg, G color compensation method	
Picture element	512(H) x 485(V) Effective	
Picture area	6.4(H) x 4.8(V) mm Effective	
Scanning system	525 lines 60 fields/30 frames 2:1 interlace NTSC system	
Scanning frequency	H: 15.734 kHz V: 59.94 Hz	
Synchronization system	Internal sync Crystal oscillation Line lock (For 60Hz power frequency only)	
Video output	VBS1.0 V _{p-p} /75Ω	
Resolution	Horizontal	330 TV lines
	Vertical	350 TV lines
Signal to noise ratio	46 dB (pp/rms) (Luminance signal) F2.8 1000 Lux 4.2 MHz LPF used	
Standard object luminance	F2.8 1000 Lux (100 fc)/3200°K Reflection ratio 89.9%	
Min. object luminance	F1.4 Approx. 20 lux (2 fc)/3200°K Reflection ratio 89.9% AGC ON	
Auto iris circuit	Built-in	
Auto white balance circuit	Built-in	
Lens mount	C-mount	
Power source	AC24V ± 10%	
Power consumption	Approx. 5.8W	
Ambient temperature	- 5°C ~ +45°C	
Outer dimensions	70(W) x 60(H) x 190(D) mm	
Weight	Approx. 1050g	
Camera mount	1/4" 20 UNC (Top and bottom)	
Connectors	Video output	BNC 1
	Power input	Terminal 1
	Auto iris lens (R05-R3F)	3P 1

■ Accessoris

- Iris connector plug 1
- Lens mount cap 1

* Specifications and outer dimensions are subject to change for improvement without notice.

* This camera is designed to produce video output signal in accordance with the NTSC system. It cannot be applied to VTR or motor with different reproduction system.

EXTERNAL VIEW DIMENSIONS

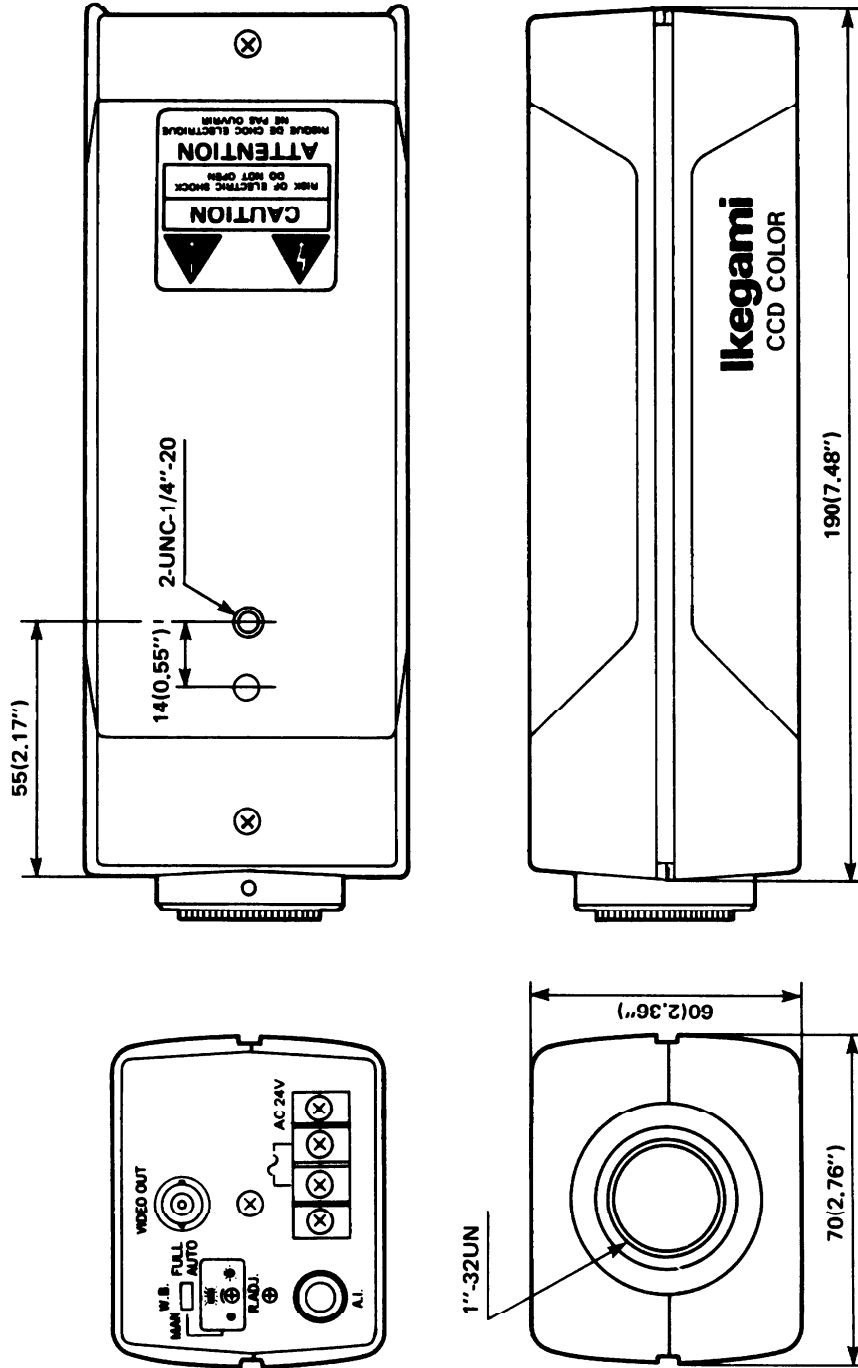

Ikegami Tsushinki Co., Ltd.

5-6-16 Ikegami, Ohta-ku, Tokyo, Japan
TEL. 03-754-2121/TLX. 2466738 IKETSU J

■ **Ikegami Electronics (U.S.A.), Inc.**

37 Brook Avenue, Maywood, New Jersey 07607, U.S.A.
Phone: (201) 368-9171, Telex: ITCNY 422065

■ **Ikegami Electronics (Europe) GmbH**

Ikegami Strasse 1, 4040 Neuss 1, F.R. Germany
TEL. 02101-123-0/TLX. 8517960 ITC D

■ **Ikegami Electronics (Europe) GmbH U.K. Branch**

Kestrel Court, Pound Road, Chertsey, Surrey KT16 8ER, England
TEL. 01-546-7772 & 0932-568966/TLX. 897005 ITC G

PRINTED IN JAPAN