

Ikegami

Ikegami Medical LCD Monitors

MLM-1581CH(15inch)

MLM-1911CHA(19inch)

MLW-2420C(24inch)



The range of Medical LCD monitors from Ikegami are all high resolution, HDTV quality with easy to use ergonomics and user friendly preset functions. They are designed to be light weight but rugged enough to withstand harsh environments in the front line of medical treatment, endoscope and microscope surgery.

All the components use in those LCD monitors are non-hazardous, toxic free, lead free and ECO friendly to meet with the latest safety regulations, such as Japan's Green Products Program, EU RoHS, CEC of the state California and other.

Ikegami medical LCD monitors are available in 15 inch, 19 inch and 24 inch, so that the best format choice can be made according to customer's requirement.

Ikegami Medical LCD Monitors

MLM-1581CH/MLM-1911CHA/MLW-2420C

Common Features of Ikegami Medical LCD monitors

Strong, Rugged construction, but Light in weight

All Ikegami medical LCD monitors are designed to withstand harsh applications and environments for a long service period. Built with a strong Aluminum Alloy frame body for easy handling in setup and also for a good anti-radiation performance.

High Resolution, Faithful Color Reproduction

All Ikegami medical LCD monitors employ a high quality LCD panel of high resolution with very natural color reproduction capability, enhanced video quality is achieved by a newly employed powerful Signal process engine.

High Performance from New Digital Process Engine

Easy viewing is assured with a smart digital process, compensating for, digital Jaggy-free lines in an interlace-progressive conversion, irritating glare from differences in each pixel and general noise generation especially in dark areas.

Very Wide Viewing Area with high contrast

Both 178 degrees, Vertical and Horizontal viewing angles are achieved ensuring much easier viewing of the panel from different positions with a high screen contrast ratio. The IK-LCD75-100-B VESA type Wall Mount Adaptor is available as an useful option for 15", 19" and 24" Ikegami LCD monitors.

Various Gamma Characteristics

5 different Gamma characters can be set, including the Standard CRT Gamma of 2.2, the DICOM Gamma and so on.

Other Useful Features

For ease of operation and for versatility, Ikegami medical LCD monitors can provide a lot of digital interface inputs and outputs, such as HD SDI, DVI as options, on top of the standard composite, Y/C and component signal provision. The user file menu comes equipped as standard with non-volatile memory for 5 different file settings on each type of input.

A screen protection panel and water-proof front control panel are available as an option.

A VESA mount with 100mm space fitting holes is provided for easy mounting with moving arms, wall mount or ceiling mount.

MLM-1581CH

The MLM-1581CH is a Multi-format 15 inch LCD monitor for easy operation with higher performance. This compact, light weight LCD monitor is an ideal tool for obtaining the highest performance in this class with 1024(H) x 768(V) XGA panel in a limited space. This IPS type LCD panel monitor comes equipped all the useful features such as high speed response, jaggy-less, non-serrated smooth picture with natural color, various analog and digital inputs. User friendly preset features and others such as 100mm VESA mount provision, Anti-reflection hard coat screen are standard.



Side Connector Panel

Front control Panel

Bottom view of Rear Panel for connectors

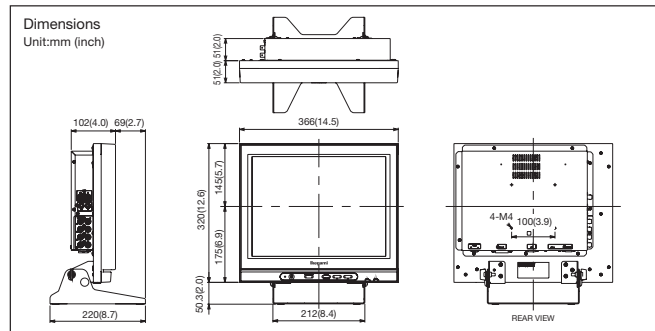

MLM-1911CHA

The MLM-1911CHA is a Multi-format 19 inch LCD monitor for specialist applications where high quality picture reproduction and true color rendition is needed. It employs a very fine LCD panel of 1280(H) x 1024(V) SXGA with a full color reproduction of 16.7 million color graduation (8 bit x 3 colors) with high brightness performance of 270cd/sq/meter. Smart jaggy-free, a non-serrated smooth natural picture can be displayed due to Ikegami's latest unique over-drive circuit. Various options are available, especially RGB input or SDI input types are available for customer's requirement by different input specifications.



Side Connector Panel



with RGB inputs with SDI inputs



Front control Panel



Bottom view of Rear Panel for connectors

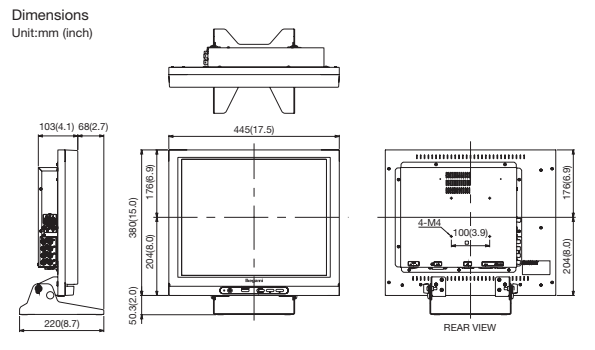

MLW-2420C

The MLW-2420C is a High Performance, Multi-format, 24 inch Wide Screen LCD monitor for specialist applications where high quality picture reproduction and true color rendition are needed. It employs a High Resolution HDTV quality 1920Hx1200V, WUXGA color LCD panel with full color reproduction of 16.7 million color graduation with high brightness performance of 400cd/square meter.

Easy Operation

The MLW-2420C comes with Multi-standard signal inputs for standard composite signals, RGB signals, HDTV 1080 HD signal, or computer signal and digital such as HD-SDI or SD-SDI as optional. The easy to use User File Menu comes equipped as standard for White Balance, Contrast and Brightness Setting. A maximum of 5 different file settings on each type of input is provided.

Very High Performance

This 24 inch diagonal WUXGA panel reproduces a very high standard picture of over 1,000 horizontal television lines resolution with a superb signal to noise ratio with very clear 400cd/square meter brightness performance. A jaggy-free, non-serrated smooth natural picture is displayed due to Ikegami's latest unique built-in over-ride circuit. All comes in a compact and light weight body.

Various Useful Options

DVI digital input and HD-SDI signal capability, Double AR coating panel (Type A) or Hard coat luster view LCD (Type G) selections, the IK-LCD75-100-B VESA wall mount adaptor for 75mm and 100mm are available as option.

This IK-LCD75-100-B Wall mount is applicable to 15" and 19" Ikegami LCD monitors.



Side Connector Panel



Front control Panel



Bottom view of Rear Panel for connectors

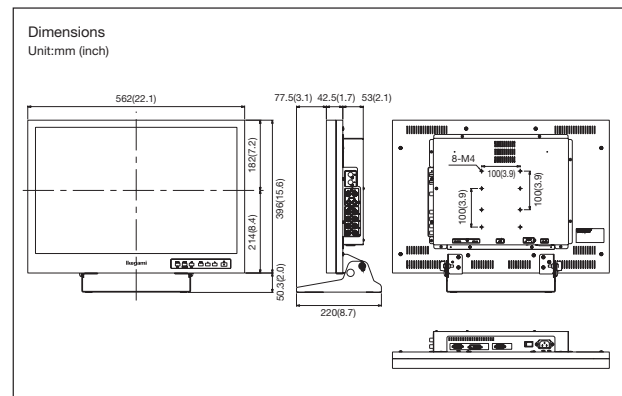

Ikegami Medical LCD Monitors MLM-1581CH/MLM-1911CHA/MLW-2420C

SPECIFICATIONS

LCD PANEL	MLM - 1581CH	MLM - 1911CHA	MLW-2420C
Size	15-inch Diagonal	19-inch Diagonal	24-inch Diagonal
Maximum Effective Display Size	304 (H) x 228 (V) mm	376 (H) x 301 (V) mm	518 (H) x 324 (V) mm
Viewing Angle	Vertical and Horizontal Viewing 178°		
Maximum Brightness	400cd/m ²	270cd/m ²	400cd/m ²
Resolution	1024 (H) x 768 (V)	1280 (H) x 1024 (V)	1920 (H) x 1200 (V)
Contrast Ratio	500 : 1	800 : 1	700 : 1
INPUT SIGNAL	(Standard)		
NTSC/PAL (Analog)	VBS x 1 channel, BNC (with loop through out) Y/C x 1 channel, S-Terminal (with loop through out)		
- Level	V:0.7Vp-p S:0.3Vp-p		
- Impedance	75 ohms ±1%		
RGB and Component (Analog)	(Standard)	(Option)	(Standard)
- Signal and Connector	Y, Pb, Pr, C-Sync x 1 channel, BNC (with loop through out)		
- Level	V:0.7Vp-p S:0.3Vp-p		
- C-Sync	1-2Vp-p		
- Impedance	75 ohms ±1%		
PC (Analog)	(Standard)	(Option)	(Standard)
- Signal and Connector	R, G, B, Hs, Vs x 1 channel, 15pin D-SUB		
- Level	V:0.7Vp-p Hs, Vs: TTL		
- Impedance	V:75 ohms±5% Hs, Vs:1K ohms±5%		
Multi-Format SDI	Nil	(Option)	(Option)
- Signal and Connector	Nil	HD/SD (4:2:2) Multi-Format SDI x 1 channel, BNC (with loop through out)	
DVI (Digital)	(Standard)	(Option)	(Standard)
- Signal and Connector	DVI-D		
- Max. Clock	108MHz		162MHz
Safety Approval	Comply with UL60601-1, CSA C22.2 No.601.1 (cUL) and EN60601-1		
EMC	Comply with FCC Class A, EN60601-1-2 and VCCI Class A		
Power Supply Voltage	AC100 to 120V, AC200 to 240V		
Power Frequency	50/60Hz		
Power Consumption	60W or less		150W or less
Ambient Temperature/Humidity	+5 to +35°C (+41.0 to 95.0°F) / 30 to 80% Non condensation		
Dimensions	366(W) x 320(H) x 102(D) mm [14-1/2(W) x 12-1/2(H) x 4(D) inch] (Excluding stand and protrusions.)	445(W) x 380(H) x 103(D)mm [17-3/4(W) x 15(H) x 4(D) inch] (Excluding stand and protrusions.)	562(W) x 396(H) x 95.5(D) mm [22-1/4(W) x 15-1/2(H) x 3-3/4(D) inch] (Excluding stand and protrusions.)
Weight	6.0kg [13-1/4lbs] approx.	8.5kg [19-1/2lbs] approx.	6.5kg [14-1/3lbs] approx.
Options	TS-191 Desktop Stand IK-LCD75-100-B VESA Wall Mount Adaptor	M-RGB1 RGB Module / M-MSDI1 Multi-Format SDI Module TW191L Touch Panel / TS-191 Desktop Stand IK-LCD75-100-B VESA Wall Mount Adaptor	M-MSDI1 Multi-Format SDI Module TS-241 Desktop Stand IK-LCD75-100-B VESA Wall Mount Adaptor

INPUT SIGNAL

Input Signal	MLM-1581CH	MLM-1911CHA	MLW-2420C
NTSC/PAL (Analog)	VBS (BNC), Y/C (S-Terminal):480i (NTSC), 575i (PAL-B)		
	Standard	Standard	Standard
Component (Analog)	R/G/B/C-Sync, Y/Pb/Pr/C-Sync (BNC):480i, 575i, 480p, 575p, 720p, 1080i		
	Standard	Optional RGB Module*	Standard
PC (Analog)	R/G/B/Hs/Vs (D-SUB, 15pin):VGA, SVGA, XGA, SXGA (Vf=60Hz)		
	Standard	Optional RGB Module*	R/G/B/Hs/Vs (D-SUB 15pin):VGA, SVGA, XGA, SXGA, UXGA, WUXGA (Vf=60Hz) Standard
PC (Digital)	DVI-D (DVI):VGA, SVGA, XGA, SXGA (Vf=60Hz)		
	Standard	Optional RGB Module*	VGA, SVGA, XGA, SXGA, UXGA, WUXGA (Vf=60Hz) Standard
Multi-SDI (Digital)	HD/SD (4:2:2) Multi-Format SDI:480i (NTSC), 575i (PAL-B), 720p, 1080i		
	Nil	Optional Multi-Format SDI Module*	Optional Multi-Format SDI Module

* This product is made of ECO friendly components based upon the Company policy and Corporate Social Responsibility to help Global Environmental solution for energy conservation and environmental sustainability, and all the components used in this product are Non-hazardous, Toxic Free, Non-Lead materials and parts conforming with Japan's Green Product Regulation, EU's RoHS Directive, and other environmental and hazardous chemical substances related regulations and laws.

* Design and specifications are subject to change without notice.

U145A0710-HI

Ikegami IKEGAMI ELECTRONICS (U.S.A.), INC. ■ URL <http://www.ikegami.com>

HEADQUARTERS 37 BROOK AVENUE, MAYWOOD, NJ 07607
Phone:(201) 368-9171 Fax:(201) 569-1626

WESTCOAST OFFICE 2631 MANHATTAN BEACH BLVD., REDONDO BEACH, CA 90278
Phone:(310) 297-1900 Fax:(310) 536-9550

SOUTHWEST OFFICE 773 BEARDEN WAXAHACHIE, TX 75167 Phone:(972) 869-2363 Fax:(972) 556-1057

MIDWEST OFFICE 747 CHURCH ROAD, UNIT C1, ELMHURST, IL 60126 Phone:(630) 834-9774 Fax:(630) 834-8689

SOUTHEAST OFFICE 5200 N.W. 33RD AVENUE, SUITE 111 FORT LAUDERDALE, FL 33309 Phone:(954) 735-2203 Fax:(954) 735-2227



Certified
JQA-0755



Certified
JQA-EM3888