



Ikegami



80 Years of Innovation

As we celebrate 80 years of innovation since our founding in September 1946, we pause to remember our valued employees and loyal customers - past, present and future. Without your commitment and support, our accomplishments would not have been possible. Cheers to the next 80 years!!

Innovation in Motion

2026-2027



LinkedIn



Online
Pocket Guide



- HDMI is a registered trademark of HDMI Licensing, LLC.
- Other products are registered trademarks or trademarks of each company.
- Design and specifications are subject to change without notice.

IKEGAMI ELECTRONICS (U.S.A.), INC.

300 STATE ROUTE 17S, MAHWAH, NJ 07430
Phone: (201) 368-9171 / Fax: (201) 569-1626

Product Pocket Guide

Leader in Broadcast Cameras, Monitors and Accessories

Contents

1. UNICAM XE Camera Series p.4

- UHK-X700/750
- UHK-X600/650
- HDK-X500

2. Base Station / Camera Control Unit p.9

- BSX-100
- CCU-X100

3. IP Extension Unit p.10

- IPX-100 **NEW**

4. Compact Cameras p.12

- UHL-X40 **NEW**
- UHL-43
- UHL-F4000

5. Accessories

Camera Controllers p.14

- OCP-500 **NEW**
- OCP-300
- MCP-300
- VCP
- VMP

Viewfinders p.16

- VFE-P711AD **NEW**
- VFL-P710AD **NEW**
- VF700WA
- VFL201D

System Expander p.17

- SE-U430

6. Monitors

4K Monitors p.18

- HQLM-3125X
- HQLM-3120W
- HQLM-1720WR

HD Monitors p.20

- HLM-2460WA
- HLM-1860WR
- HLM-960WR
- ULE-315U
- ULE-217-HDR
- ULE-217A
- ULE-185U

UNICAM XE Camera Series



With newly incorporated features and uncompromising image quality, the UNICAM XE family covers all aspects of advanced broadcasting production from standard 4K/HD footage to high frame rates and XR applications effectively and efficiently. Choose your UNICAM XE and experience a more versatile and streamlined production workflow.

Con nuevas funciones incorporadas y una inigualable calidad de imagen, la serie UNICAM XE cubre todos los aspectos de la producción de programas televisivos. Se entrega video en formatos 4K/HD como estándar, captura en alta velocidad y, facilita la integración con aplicaciones XR (realidad extendida). Elija su modelo serie UNICAM XE y realice la experiencia de un flujo de producción más versátil y optimizado.

LINEUP

UHK-X700

4K/HD Portable Camera System

4K HFR MoIP	2/3-inch B4	4K 2160p	62dB SNR	Sensitivity F10
	ST 2110*	JPEG XS*	Anti-Moiré Filter	4K out direct from the head
	4x speed* (HD)	8x speed* (HD)	2x speed* (4K)	

UHK-X750

4K/HD Studio Camera System

UHK-X600

4K upgradeable
HD Portable Camera System

4K HFR MoIP	2/3-inch B4	4K 2160p	62dB SNR	Sensitivity F10
	ST 2110*	JPEG XS*	Anti-Moiré Filter	4K out direct from the head
	4x speed* (HD)			

UHK-X650

4K upgradeable
HD Studio Camera System

HDK-X500

HD Portable Camera System

HD MoIP	2/3-inch B4	3G 1080p	62dB SNR	Sensitivity F11
	ST 2110*	JPEG XS*	Anti-Moiré Filter	

*Features available when connected with:

	BSX-100, CCU-X100	IPX-100
ADV-HFR (HD) 4x speed	✓	✓
EXT-HFR (HD) 8x, (4K) 2x speed	✓	
ST 2110	✓	✓
JPEG XS		✓

Option

Features

Global Shutter CMOS Sensor

A newly developed CMOS sensor enables the camera to capture natural images.

El desarrollo de un nuevo dispositivo de imagen tipo CMOS permite capturar imágenes libres de distorsiones geométricas.

Rolling Shutter CMOS



Geometric Distortion

Global Shutter CMOS



No Rolling Shutter Artifacts with Global Shutter

HFR

A choice of HFR options provide a maximum of 2x speed in 4K and up to 8x speed in HD.

Se proporciona como opción capturar imágenes en altas velocidades de X2 en UHD (4K) y X8 en HDTV.

ADV-HFR : 2, 3, and 4x speed in HD for UHK-X700/750, 600/650

EXT-HFR : Additionally 6 and 8x speed in HD, 2x speed in 4K for UHK-X700/750 *Not available with IPX-100



HDR

HDR is supported by the HLG (Hybrid Log Gamma) system as standard.

Con la función estándar HLG (Gama Híbrida Logarítmica) se incluye la función del alto alcance dinámico (HLG).

SDR



Standard Dynamic Range

HDR



High Dynamic Range

*Simulated images

MoIP

All UNICAM XE series cameras are designed to support interoperability with ST2110 media-over-IP networks when connected with the IPX-100 or by incorporating an optional MoIP Module at the BSX-100/CCU-X100.

An optional MoIP output board cannot be installed concurrently with the 12G-SDI output module for the BSX-100/CCU-X100.

Las cámaras serie UNICAM XE están diseñadas para operar en redes multimedia IP tipo ST-2110 empleando el IPX-100 o incorporando un módulo MoIP opcional instalado dentro de la base BSX-100 o unidad control de cámara CCU-X100.

Al instalar el módulo opcional MoIP, se impide el uso de la opción que permite salidas en 12G SDI con las BSX-100 o CCU-X100.



IPX-100

BSX-100

Ergonomic Design

The weight distribution has been totally refined from its predecessor model. A lower center of gravity and a well-balanced body help to reduce operator fatigue.

La distribución del peso de la cámara ha sido mejorada. Además, y con un centro de gravedad más bajo, estos beneficios son enormes avances para reducir la fatiga del camarógrafo.



Wide adjustable range of shoulder pad
Hombreira con amplio rango de ajuste.



Shoulder pad is placed 30 mm forward of the previous model

La posición de la hombreira se mejora por 30mm comparado al modelo anterior.



Improved field-of-view over the camera
Amplia vista lateral disponible al camarógrafo.

Features

Remote Back Focus Adjustment (RBF)

The OCP-500/300 can remotely adjust the back focus of a zoom lens.

* Easy operation with Tele & Wide buttons. Ideal solution for critical focusing accuracy.

Los paneles de control remoto OCP-300 y OCP-500 permiten un preciso ajuste parfocal del lente. Se provee botones que actúan el zoom del lente, facilitando este ajuste.



*with supported lenses

Optical Vignetting Correction (OVC)

- F-drop compensation with vignetting correction

- Se compensa perdidas en luminosidad al operar el zoom tal como el efecto del viñeteado.

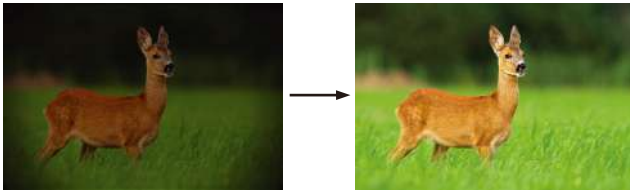

*with supported lenses

Robust Mode

(optional, available in HD system format)

Robust Mode optimizes the occupied bandwidth in HD system format, mitigating the dependence on fiber link quality while maintaining stable camera-to-CCU transmission.

El modo de robustez optimiza el ancho de banda ocupado en formato de sistema HD. De tal forma, se mitiga la dependencia de la calidad del enlace de fibra mientras se sostiene una transmisión estable entre la cámara y la CCU.

BSX-100

4K/HD Base Station

HFR
MoIP



The BSX-100 is a universal base station for both 4K and HD camera systems.

La BSX-100 es una base-estación universal para sistemas de cámaras 4K y HD.

Cable length: 3,500m (11,500ft)	12G-SDI Interface*	Size: 3RU Half
4K/HD simulcast	TSL Tally V5.0	MoIP ST2110 Compliance NMOS IS-04 & 05 12G-SDI Output

*option for type-H&S

CCU-X100

4K/HD Camera Control Unit

HFR
MoIP



The CCU-X100 is the perfect choice for field production purposes where greater cable length is required.

El CCU-X100 es la opción perfecta para la producción al campo cuando se requiere una mayor longitud de cable.

Cable length: 4,000m (13,123ft)	12G-SDI Interface*	Size: 3RU Full
4K/HD simulcast	TSL Tally V5.0	MoIP ST2110 Compliance NMOS IS-04 & 05 12G-SDI Output

*option for type-H&S

BS/CCU TYPE:	Supported Cameras:
Type-H	Unicam HD, HDK-X500
Type-S	UHK-X600/650
Type-U	UHK-X600/650, UHK-X700/750
Type-M	Unicam HD & UNICAM XE

Option

IP Extension Unit Unidad de extensión IP

IPX-100



IP Extension Unit



The IPX-100 is an external IP gateway for UNICAM XE and Unicam HD cameras.

El IPX-100 ofrece un puente de interface entre redes de tráfico multimedia por IP con ambas cámaras series UNICAM XE y UNICAM HD.

Cable length: 3,500m (11,500ft)	Size: 2RU Half	TSL Tally V5.0
MoIP ST2110 Compliance NMOS IS-04 & 05	4K/HD simulcast	JPEG XS

Option

■ Ideal for IP Remote Production

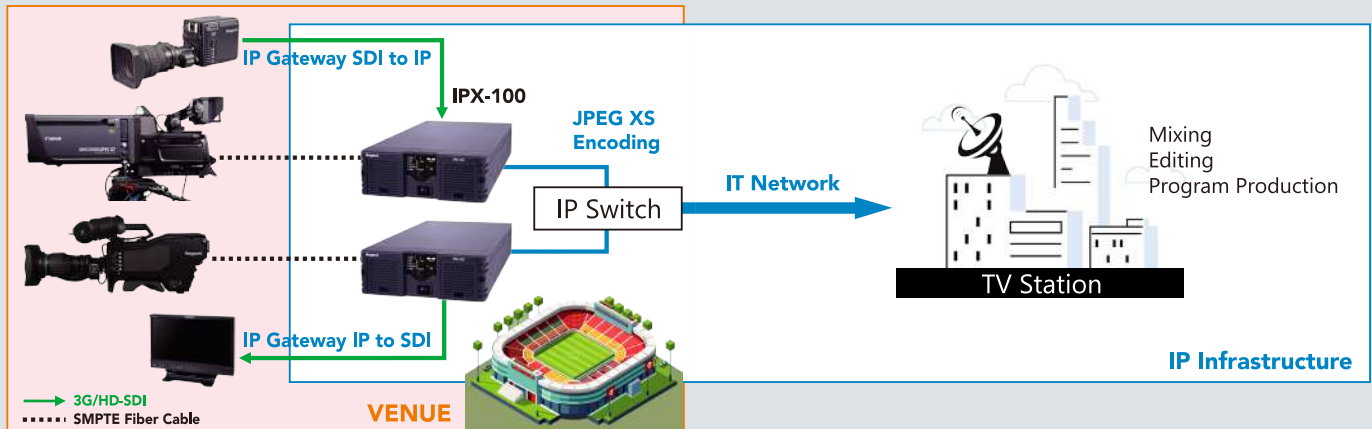

Optional Features

■ 4K HDR / HD SDR Simulcast

The HD output is processed from the original 4K HDR image with a 3D LUT, ensuring more accurate color and tone mapping with improved color consistency in the downconverted image.

Las salidas HD, derivadas de las imágenes 4K HDR originales, emplean algoritmos 3-dimensionales en la conversión de matrices de color. Esto provee un color equivalente, tonalidades más precisas y con gran consistencia.

■ JPEG XS

The IPX-100 provides selectable data rate in four steps: High (1/5), Mid (1/8), Low (1/16), and Mini (1/32), allowing users to choose an optimal setting according to operational conditions.

El IPX-100 permite seleccionar entre varias tasas de datos: Alta (1/5); Media (1/8); Baja (1/16); y Mini (1/32). Esto capacita elegir un flujo óptimo de datos cuando las condiciones operativas así lo requieran.

■ IP Gateway function

An optional IP Gateway function utilizes one stream in each direction for external input and output, allowing SDI devices to seamlessly connect to the ST 2110 media-over-IP network.

La función "Puente IP" opcionalmente otorga un flujo IP en cada dirección como entradas SDI. Esta facilita el transporte del SDI entre redes IP multimedia tipo ST-2110.

UHL-X40

NEW

4K/HD Separate Optics Camera

4K
HDR



2/3-inch B4	4K 2160p	62dB SNR	Sensitivity F10
2.4 lbs camera head	2-piece construction		Tally Support
Global Shutter 3CMOS sensors	HDR	HD cutout	RBF*
OVC*			

*with supported lenses

HD Simultaneous Output

The HD outputs from the CCU can be selected between the full UHD frame (3840 x 2160) that is natively captured or, the center area of interest as an HD (1920 x 1080) signal cutout from the native UHD frame. Two angles of view of the same scene and both formats are simultaneously output.

Simultáneamente desde el CCU, se provee el HD derivado del cuadro 4K nativo. El HD es un recorte (1920x1080) ubicado al centro del cuadro 4K. Esto permite obtener dos ángulos de vista, de la misma toma.

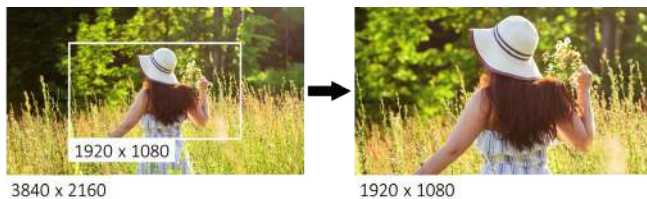

*Simulated images

UHL-43

4K/HD Multi-Purpose Compact Camera

4K
HDR



2/3-inch B4	4K 2160p	62dB SNR	Sensitivity F10
12G-SDI Interface	BT2020 & BT709	HDR	16-Axis CC

Option

UHL-F4000

4K/HD Low Light Airborne Camera

4K
HDR



2/3-inch B4	4K 2160p	62dB SNR	Sensitivity F12
2.4 lbs camera head	2-piece construction		Gain: Up to +72db
Global Shutter 3CMOS sensors	HDR	HD cutout	RBF*
Vibration Resistant	Image Flip		

*with supported lenses

Camera Controllers

OCP-500 **NEW** OCP-300



- Ethernet
- Serial IF
- USB Memory
- Touch Screen
- Unicam XE
Unicam HD
- Slim Type
- Multi-Cam Select



- Ethernet
- Serial IF
- SD Card
- Touch Screen
- Unicam XE
Unicam HD
- Multi-Cam Select

OCP-100



- Serial IF
- Unicam HD

MCP-300



- Ethernet
- Serial IF
- SD Card
- Touch Screen
- Unicam XE
Unicam HD
- Master Control

VCP

Virtual Control Panel



VMP

Virtual Master Panel



Option

ICCP•Ethernet

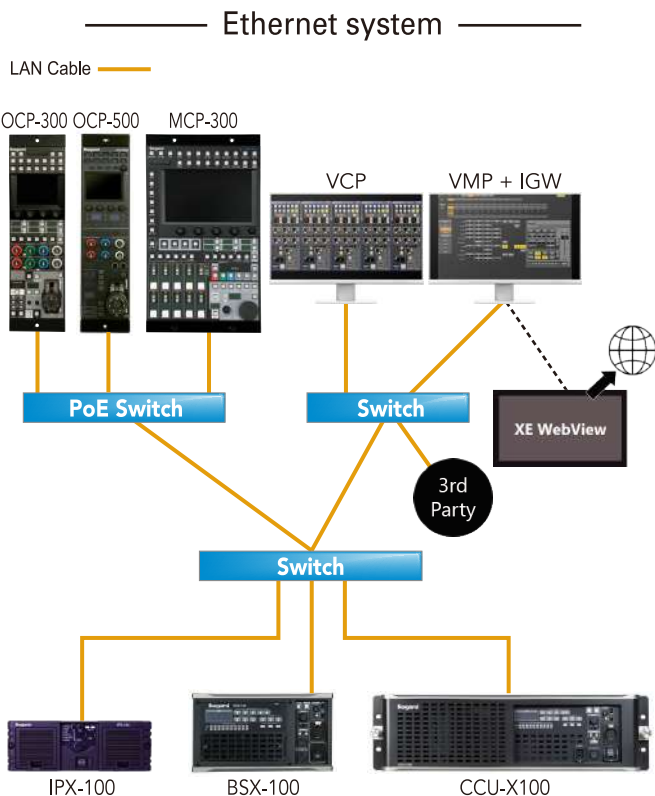
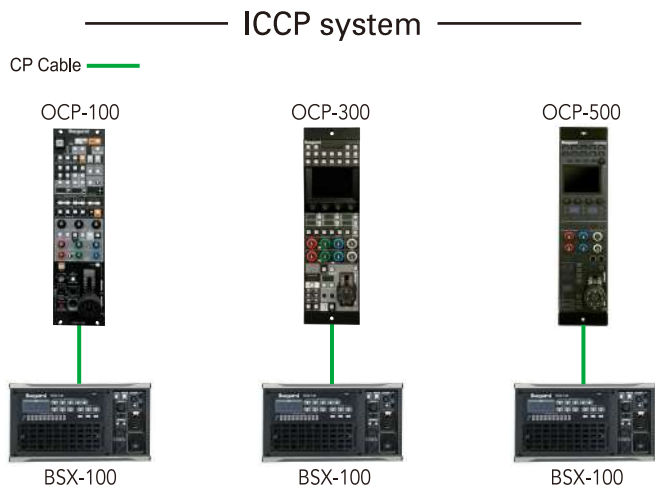

7-inch Viewfinders



NEW

VFE-P711AD
7-inch OLED
Viewfinder



NEW

VFL-P710AD
7-inch LCD
Viewfinder



VF 700WA
7-inch LCD
Viewfinder

2-inch Viewfinders



VFL 201D
2-inch LCD
Viewfinder

System Expander

SE-U430



The SE-U430 System Expander enables the use of studio lenses with Unicam XE series cameras, converting the portable camera into a full facility studio camera.

El expansor de sistema SE-U430 facilita el empleo de lentes largos con cámaras serie Unicam XE, convirtiéndolas a cámaras de estudio con todas las comodidades operativas.

Multi-Format 4K LCD Monitors Monitores 4K LCD multi-formato

HQLM-3125X

31-inch 4K/HD Multi-format
LCD Master Monitor

HDMI™
4K
HDR



31-inch 4K LCD	4096x2160 pixel			
178° (H/V)	Contrast 1M : 1	1,000 nits	BT.2020	DCI-P3 D65
DCI-P3	ACES	Adobe RGB	12G-SDI	3G/HD-SDI
HDMI (HDCP)	Embedded Audio	Analogue Audio Out	HDR HLG/PQ	HD/UHD (2K/4K)
UMD IMD	3D LUT CC	Gamut Marker	VITC/LTC	WFM
Vectorscope	CC	30 x 18.39 x 6.77 inches (762 x 467 x 172 mm)	66.14 lbs (30 kg)	

HQLM-1720WR

17-inch 4K/HD Multi-format
LCD Monitor

HDMI™
4K
HDR



17-inch 4K LCD				
3840x2160 pixel	178° (H/V)	Contrast 800 : 1	450 nits	BT.2020
DCI-P3	ACES	Adobe RGB	12G-SDI	3G/HD-SDI
HDMI (HDCP)	Embedded Audio	Analogue Audio Out	HDR HLG/PQ	HD/UHD (2K/4K)
UMD IMD	VITC/LTC	WFM	Vectorscope	CC
	16.85 x 12.17 x 5.7 inches (428 x 309 x 145 mm)	7 RU	18.74 lbs (8.5 kg)	Auto Calibration

HQLM-3120W

31-inch 4K/HD Multi-format
LCD Monitor

HDMI™
4K
HDR



31-inch 4K LCD	4096x2160 pixel	178° (H/V)	Contrast 1,500 : 1	350 nits
BT.2020	DCI-P3	ACES	Adobe RGB	12G-SDI
3G/HD-SDI	HDMI (HDCP)	Embedded Audio	Analogue Audio Out	HDR HLG/PQ
HD/UHD (2K/4K)	UMD IMD	VITC/LTC	WFM	Vectorscope
CC	29.52 x 18.07 x 4.21 inches (750 x 459 x 107 mm)	31.96 lbs (14.5 kg)	Auto Calibration	

Features

Diverse Input Signal Formats

Available with 12G-SDI, 3G-SDI (SQD/2SI), HD-SDI and HDMI (HDCP2.2) inputs as standard.

Disponible con entradas estándar 12G-SDI, 3G-SDI (SQD/2SI), HD-SDI y HDMI (HDCP2.2)

Faithful Color Reproduction

It provides a wide color gamut corresponding to the ITU-R BT.2020 standard.

Proporciona una amplia gama de colores correspondiente al estándar ITU-R BT.2020.

UHD LCD Panel

It employs UHD LCD panel. The monitor has a wide viewing angle within a horizontal or vertical viewing angle of up to 178 degrees.

Se emplea pantalla tipo UHD LCD la cual permite ángulos de vista horizontal y vertical mayor a 178 grados.

Supports Audio Signals

Audio output is available through internal stereo speakers, stereo headphone jack and stereo line out by automatic identification of embedded audio signals multiplexed into the SDI or HDMI signal.

Los canales de audio embebidos en las señales de entrada SDI o HDMI se reproducen a través de parlantes integrados, salidas de audífonos estéreo y conectores discretos ubicados en el trasero del monitor.

Multi-Format HD LCD Monitors Monitores HD LCD multi-formato

60 Series Monitors

HLM-2460WA

24-inch Full HD Multi-format LCD Monitor

HDMI
HDR



24-inch WUXGA	1920x1200 pixel	178° (H/V)	Contrast 1,800 : 1	400 nits
3G/HD-SDI	HDMI (HDCP)	CVBS	Embedded Audio	Analogue Audio I/O
UMD IMD	VITC/LTC	WFM	Vectorscope	CC
Split Screen	P-in-P	Zoom Display	TSL Tally V5.0	9 RU
22.1 x 15.7 x 3.4 inches (562 x 398 x 86 mm)		20.1 lbs (9.1 kg)	HDR	Auto Calibration

HLM-1860WR

18.5-inch Full HD Multi-format LCD Monitor

HDMI
HDR



18.5-inch Full HD	1920x1080 pixel	178° (H/V)	Contrast 1,000 : 1	500 nits
3G/HD-SDI	HDMI (HDCP)	CVBS	Embedded Audio	Analogue Audio I/O
UMD IMD	VITC/LTC	WFM	Vectorscope	CC
Split Screen	P-in-P	Zoom Display	TSL Tally V5.0	7 RU
17.3 x 12.2 x 3.2 inches (440 x 301 x 80 mm)		13.01 lbs (5.9 kg)	HDR	Auto Calibration

HLM-960WR

9-inch Full HD Multi-format LCD Monitor

HDMI
HDR



9-inch Full HD	1920x1080 pixel	178° (H/V)	Contrast 700 : 1	400 nits
3G/HD-SDI	HDMI (HDCP)	CVBS	Embedded Audio	Analogue Audio I/O
UMD IMD	VITC/LTC	WFM	Vectorscope	CC
Split Screen	P-in-P	Zoom Display	TSL Tally V5.0	4 RU
8.8 x 6.8 x 2.8 inches (222.4 x 173 x 69.5 mm)		3.75 lbs (1.7 kg)	HDR	Auto Calibration

High Dynamic Range (Option)

The 60 series monitors support HDR (High Dynamic Range) EOTF tables of HLG1, HLG2, and S-Log3 as an option in addition to conventional gamma.

Opcionalmente los monitores serie 60 aceptan HDR (alto rango dinámico) de HLG1, HLG2 y S-Log3 y como función estándar, la curva de gamma fija convencional.



SDR Picture



HDR Picture

*Simulated images

Option

ULE-315U

31.5-inch 3G-SDI Full HD Professional Monitor



31.5-inch Full HD	1920x1080 pixel	55W	Viewing Angle (H/V) 178/178°	
Contrast 1,400 : 1	3G/HD/SD -SDI	HDMI	VGA	CVBS
Analog Audio 2ch Input		28.81 x 19.14 x 6.29 inches (732.0 x 486.3 x 160.0 mm)		28.43 lbs

ULE-217A

21.5-inch Full HD Professional Monitor



21.5-inch Full HD	1920x1080 pixel	24W	Viewing Angle (H/V) 178/160°	
Contrast 1,000 : 1		VBS Input	3G/HD-SDI	HDMI
Analog Audio 2ch Input		VGA	DVI	
20.27 x 15.35 x 1.96 inches (515 x 390 x 50 mm)		5.42 lbs		

ULE-217-HDR

21.5-inch 3G-SDI Full HD HDR Monitor

HDR



21.5-inch Full HD	1920x1080 pixel	24W	Viewing Angle (H/V) 178/178°	
Contrast 1,000 : 1		3G/HD-SDI	HDMI	VGA
20.32 x 13.65 x 1.72 inches (516.0 x 346.9 x 43.6 mm)		8.4 lbs		

ULE-185U

18.5-inch HD Professional Monitor



18.5-inch Full HD	1366x768 pixel	24W	Viewing Angle (H/V) 178/170°	
Contrast 1,000 : 1		VBS Input	3G/HD-SDI	HDMI
Analog Audio 2ch Input		VGA	DVI	
17.64 x 11.72 x 3.58 inches (448.1 x 297.7 x 90.9 mm)		3.58 lbs		